



Sospesi nel tempo

Ma il tempo è ciclico: una storia di eterni ritorni?
Oppure è lineare: una freccia sparata dal buio fondo del passato
agli abissi incandescenti del futuro?
Importa davvero stabilirlo? La risposta è no.
Anzi NO, tutto in maiuscole.
L'estetica contemporanea, pixellata e in streaming continuo,
è fatta di compresenze, innesti, inaudite congiunzioni.
Tradizione e innovazione, ornato e linearità,
semplificazione e decoro,
percepiti una volta come categorie inconciliabili,
sono oggi direttrici che si intersecano,
creando nuovi, eccitanti scenari nei quali
presente e passato si sovrappongono.
Classico non è più l'opposto di moderno.
Semplicemente perché il moderno, quando è veramente tale,
cattura lo spirito dei tempi sublimandolo in un segno atemporale,
dunque classico; e così il classico,
in quanto fuori dal tempo, è moderno.
La conciliazione degli opposti è il valore.
Un progetto riuscito rompe il ciclo in una sintesi:
è sospeso, al di sopra e al di fuori del tempo.
Masiero ne è la prova.

MASIERO[®]

What about time: is it cyclical, an eternal comeback?
Or is it linear, an arrow propelled from the darkness
of the past to the bright abysses of the future?
Is there really an urge to define? The answer is no. NO, all in capitals.
Composed of a copious amount of pixels in endless streaming,
contemporary esthetic relies on simultaneous presences,
crossings, challenging conjunctions.
overlap creating new, exciting scenarios
in which past and present are one.
Classic is not anymore the polar opposite of modern,
simply because modern, when it really is modern,
catches and sublimates the zeitgeist in a timeless sign
which is intimately classic; classic, on the other hand,
when timeless, is resolutely modern.
Conciliation of opposites is a value.
A successful project breaks the cycle in a synthesis
suspended above and out of time.
Masiero offers proof.



What about time: is it cyclical, an eternal comeback?
Or is it linear, an arrow propelled from the darkness
of the past to the bright abysses of the future?
Is there really an urge to define? The answer is no. NO, all in capitals.
Composed of a copious amount of pixels in endless streaming,
contemporary esthetic relies on simultaneous presences,
crossings, challenging conjunctions.
overlap creating new, exciting scenarios
in which past and present are one.
Classic is not anymore the polar opposite of modern,
simply because modern, when it really is modern,
catches and sublimates the zeitgeist in a timeless sign
which is intimately classic; classic, on the other hand,
when timeless, is resolutely modern.
Conciliation of opposites is a value.
A successful project breaks the cycle in a synthesis
suspended above and out of time.
Masiero offers proof.

What about time: is it cyclical, an eternal comeback?
Or is it linear, an arrow propelled from the darkness
of the past to the bright abysses of the future?
Is there really an urge to define? The answer is no. NO, all in capitals.
Composed of a copious amount of pixels in endless streaming,
contemporary esthetic relies on simultaneous presences,
crossings, challenging conjunctions.
overlap creating new, exciting scenarios
in which past and present are one.
Classic is not anymore the polar opposite of modern,
simply because modern, when it really is modern,
catches and sublimates the zeitgeist in a timeless sign
which is intimately classic; classic, on the other hand,
when timeless, is resolutely modern.
Conciliation of opposites is a value.
A successful project breaks the cycle in a synthesis
suspended above and out of time.
Masiero offers proof.

What about time: is it cyclical, an eternal comeback?
Or is it linear, an arrow propelled from the darkness
of the past to the bright abysses of the future?
Is there really an urge to define? The answer is no. NO, all in capitals.
Composed of a copious amount of pixels in endless streaming,
contemporary esthetic relies on simultaneous presences,
crossings, challenging conjunctions.
overlap creating new, exciting scenarios
in which past and present are one.
Classic is not anymore the polar opposite of modern,
simply because modern, when it really is modern,
catches and sublimates the zeitgeist in a timeless sign
which is intimately classic; classic, on the other hand,
when timeless, is resolutely modern.
Conciliation of opposites is a value.
A successful project breaks the cycle in a synthesis
suspended above and out of time.
Masiero offers proof.

MASIERO[®]

E C'È TUTTO. IL PASSATO, IL FUTURO E LO SCAVARE DENTRO LA MENTE PER PORTARE ALLA LUCE QUELLO CHE È DENTRO DI NOI, MA CHE NON ABBIAMO MAI VISTO.

Non è facile guardare avanti verso il futuro, eppure la linea Masiero in qualche modo anticipa forme di design che sono ancorate al passato, ma guardano verso il nuovo.

E' una ricerca di linee nuove che si intrecciano, sovrappongono, oltrepassano lo stile più classico, ma senza mai negare la continuità e le proprie radici. Lampadari in stile "minimalista" con tutto quello che il termine significa a partire dagli anni '60 in poi.

Minimalista è la sobrietà della forma che nel suo essere scarno vuole solo mostrare ciò che è.

Ma minimalista è anche tutto quello che inevitabilmente l'oggetto ci comunica e tutto ciò che noi vogliamo vedere nell'oggetto. Minimalista sembra la negazione dell'arte e pare che quasi tutti noi, con un po' di fantasia, sia possibile eguagliare se non fosse che i "codici"

del minimalismo hanno tale complessità e particolarità -rispetto ad esempio al linguaggio puramente figurativo- che solo ore di lacrime e sangue possono generare. E i "codici" non si colgono a colpo d'occhio, ma con l'intuizione della mente, di categorie concettuali: "cose che voi umani non potreste immaginarvi". Cose che chi ha penetrato i segreti del futuro non può comunicare perché il futuro non ci appartiene.

Ma la linea Masiero riesce a comunicare perché lega e salda il futuro col passato e il passato ci è dentro.

E' la lampada al laser nel tinello marrone del Dr. Freud nella Vienna di inizio '900.

E c'è tutto. Il passato, il futuro e lo scavare dentro la mente per portare alla luce quello che è dentro di noi, ma che non abbiamo mai visto.

MASIERO

ECLETTICA

It is not easy to look to the future, but somehow the Masiero line is in the vanguard of new designs that are rooted in the past but look ahead. It is a research into new lines that interweave, overlap and exceed the most classic of styles without ever denying continuity and their roots. Minimalist lamps, with everything the term has meant since the beginning of the 60s. Minimalist means sober forms which in their simplicity show all of themselves, but minimalist is also everything that the item communicates and everything we want to see in it. Minimalist seems the negation of art and it seems that all of us, with a bit of imagination, can equal it if it were not for the fact that the minimalist "codes" are extremely complex and peculiar – with respect to the purely figurative language for example – that only hours of tears and blood can create. The "codes" are not grasped at a simple glance but through mental intuition and conceptual codes: "things that you humans could never imagine". Things that whoever has penetrated the secrets of the future cannot communicate to us, because the future does not belong to us. But the Masiero line gets the message over because it ties and welds the future to the past and the past is inside us. Laser lamps in Dr. Freud's brown bath in Vienna at the beginning of the 20th century. *It is everything. Past, future and digging into the mind to bring to light whatever is inside us but which we have never seen before.*

Il n'est pas facile de regarder vers le futur, et pourtant la ligne Masiero anticipe en quelque sorte les formes de design qui sont ancrées dans le passé, mais qui regardent vers le nouveau. C'est une recherche de lignes nouvelles qui s'entrelacent, se superposent, dépassent le style le plus classique, sans toutefois jamais nier la continuité et ses racines. Des lustres dans un style « minimaliste » avec tout ce que ce terme signifie à partir des années soixante. Minimaliste signifie la sobriété de la forme qui ne veut dans son essentiel que montrer ce qu'elle est. Mais minimaliste est aussi tout ce que l'objet nous communique inévitablement et tout ce que nous voulons voir dans cet objet. Minimaliste semble vouloir dire négation de l'art et que presque tous ceux d'entre nous peuvent, avec un peu d'imagination, l'égaliser, si ce n'est que les "codes" du minimalisme sont tellement complexes et particuliers – par exemple par rapport au langage purement figuratif – que seules des heures de larmes et de sang peuvent en dériver. Et les « codes » ne sont pas compréhensibles en un seul coup d'œil, mais avec l'intuition de l'esprit, de catégories conceptuelles : "des choses que vous humains ne pourriez vous imaginer." Des choses que ceux qui ont pénétré les secrets du futur ne peuvent pas communiquer parce que le futur ne nous appartient pas. Cependant, la ligne Masiero réussit à communiquer parce qu'elle lie et soude le futur avec le passé et le passé est à l'intérieur de nous. C'est la lampe au laser dans le cabinet marron du Dr. Freud dans la Vienne du début du XIXe siècle. *Et tout est présent. Le passé, le futur et la capacité de creuser dans l'esprit pour porter à la lumière ce qu'il y a en nous, mais que nous n'avons jamais vu.*

Es ist nicht einfach, nach vorne, in die Zukunft zu blicken. Und doch nimmt die Linie Masiero irgendwie Designformen vorweg, die in der Vergangenheit wurzeln, gleichzeitig aber auf das Neue ausgerichtet sind. Eine Suche nach neuen Linien, die sich verflechten, überlagern und über den rein klassischen Stil hinaus gehen, ohne jedoch jemals die Kontinuität und ihre Wurzeln abzuleugnen. Lampen im "minimalistischen" Stil, mit all dem, was der Begriff seit den 60er Jahren bedeutet. Minimalistisch ist die Schlichtheit der Formen, die in ihrer nüchternen Art nur das zeigen will, was sie ist. Doch minimalistisch ist auch all das, was uns der Gegenstand unweigerlich mitteilt, und all das, was wir in diesem Gegenstand sehen wollen. Minimalistisch scheint die Negation der Kunst, und es sieht so aus, als ob wir es ihr fast alle, mit etwas Fantasie, gleich tun können, wenn sich die "Regeln" des Minimalismus nicht – im Vergleich zur rein figurativen Sprache – durch eine derartige Komplexität und Besonderheit auszeichnen würden, dass sie nur durch lange Stunden des Tränen- und Blutvergießens geschaffen werden können. Und die "Regeln" erfasst man nicht auf einen Blick, sondern dank der Intuition des Verstandes, der begrifflichen Kategorien: "Dinge, die Ihr Menschen niemals glauben würdet". Dinge, die uns von denjenigen, die glauben, die Geheimnisse der Zukunft durchdrungen zu haben, nicht übermittelt werden können, weil uns die Zukunft nicht gehört. Doch der Linie Masiero gelingt es, zu kommunizieren, weil sie die Zukunft fest mit der Vergangenheit verbindet, und weil die Vergangenheit in ihr steckt. Sie ist die Laserleuchte im braunen Wohnzimmer von Dr. Freud in der Stadt Wien zu Anfang des 20. Jahrhunderts. *Alles ist da. Die Vergangenheit, die Zukunft, das Erforschen des Geistes, um das ans Licht zu bringen, was in uns steckt, was wir aber nie zuvor gesehen haben.*

No es fácil mirar hacia adelante hacia el futuro y sin embargo la línea Masiero de algún modo anticipa formas de diseño que están ancladas en el pasado pero que miran hacia lo nuevo. Es una búsqueda de líneas nuevas que se entrelazan, se superponen, superan el estilo más clásico, pero sin negar nunca la continuidad y las propias raíces. Lámparas de estilo "minimalista" con todo lo que el término significa de los años 60 en adelante. Es minimalista la sobriedad de la forma que en su esencialidad sólo quiere mostrar lo que es. Pero también es minimalista todo lo que inevitablemente el objeto nos comunica y todo lo que nosotros queremos ver en el objeto. Parece minimalista la negación del arte y parece que para casi todos nosotros, con un poco de imaginación, sería es posible igualar si no fuera porque los "códigos" del minimalismo tienen una complejidad y una particularidad tales – respecto por ejemplo al lenguaje puramente figurativo - que sólo horas de lágrimas y sangre pueden generar. Y los "códigos" no se captan a primera vista, sino con la intuición de la mente, de categorías conceptuales: "cosas que vosotros humanos no podríais imaginaros". Cosas que para quien ha ahondado en los secretos del futuro no puede comunicar porque el futuro no nos pertenece. Pero la línea Masiero logra comunicar porque enlaza y une el futuro con el pasado y el pasado está dentro. Es la lámpara de láser en el tinaco marrón del Dr. Freud en la Viena de principios del siglo XX. Y hay de todo. *El pasado, el futuro y el ahondar dentro de la mente para sacar a la luz lo que está dentro de nosotros, pero que nunca hemos visto.*



INDEX

AÏSSI

242

ANIMA

10

ARTÉ

76

ARTÉ LINEAR

86

AUREA

326

BALOON

310

BIANCOMURANO

150

BLOB

198

CLICK

274

CUBIX

340

DECÒ

34

DONNA

218

DORÉ

52

EVA

62

FANTASIA

266

FLORA

142

FLUTÉ

316





ANIMA

Design by: Manuel Vivian



Anima PL6



Anima PL6



Anima PL6





Anima S1



Anima S1



Anima PL3



Anima A2



Anima A2

ANIMA

Design by: Manuel Vivian

Montatura metallica verniciata bianca e goccia sospesa di cristallo, soffiato e lavorato a mano.

White-enamelled metal mount and hand worked and blown hanging crystal drop.

Weiß lackierte Metallfassung mit hängendem Kristallglastropfen, geblasen und von Hand gearbeitet.

Monture métallique vernie blanche et pampille suspendue en cristal soufflé faite à la main.

Montura metálica pintada blanca y gota colgante de cristal, soplado y elaborado a mano.

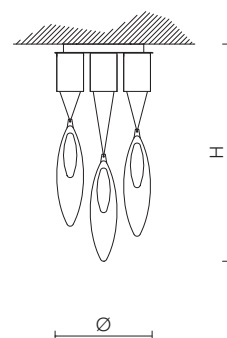
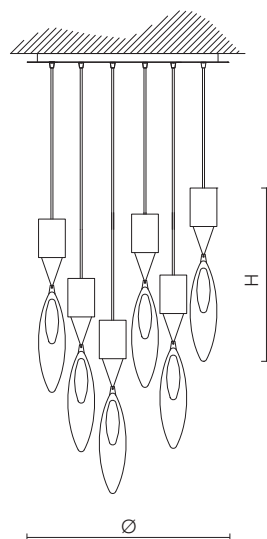
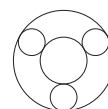
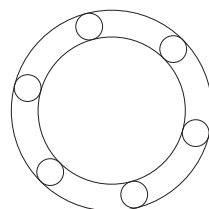

ANIMA PL6

H 60 cm
23.70"

Ø 60 cm
23.70"

W 6x35w



6xGU10
Dicroica

ANIMA PL3

H 55 cm
21.70"

Ø 30 cm
11.90"

W 3x35w



3xGU10
Dicroica





ARG
Argento

AZZ
Acquamarina

RUB
Rubino

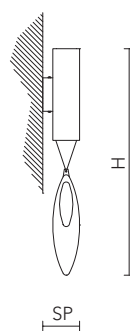
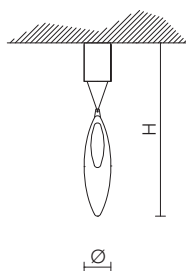
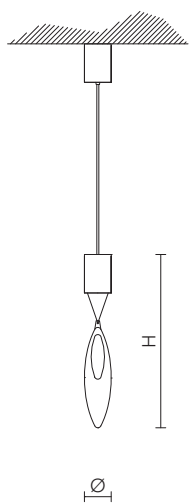

ANIMA S1

H 40 cm
15.80"

Ø 10 cm
4.00"

W 1x35w



ANIMA PL1

H 40 cm
15.80"

Ø 10 cm
4.00"

W 1x35w



ANIMA A2

H 60 cm
23.70"

Ø 10 cm
4.00"

SP 11 cm
4.40"

W 2x35w



SASSO

Design by: Manuel Vivian



Sasso APL4 RC

Sasso APL3 RC









Sasso APL3



SASSO

Design by: Manuel Vivian

Diffusori in vetro soffiato
montatura metallica
verniciata a polvere in
bianco, diffusore in vetro
triplex di colore bianco.

Blown glass lights, white,
dust-enamelled metal
mount, shade in white
triplex glass.

Diffusoren aus
geblasenem Glas,
Metallfassung mit weißer
Pulverlackierung, Diffusor
aus weißem Triplexglas.

Diffuseurs en verre
soufflé, monture de métal
vernée à poudre couleur
blanche, diffuseur en
verre triplex blanc.

Difusores de vidrio
soplado montura metálica
pintada de polvo blanco,
difusor de vidrio triplex
de color blanco.

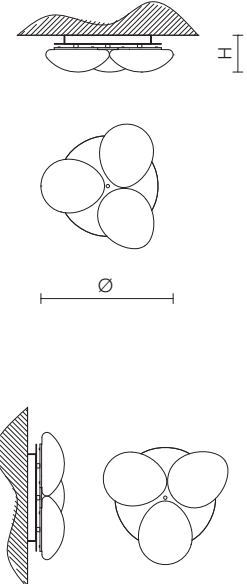
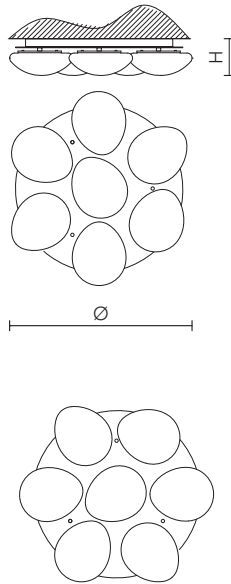
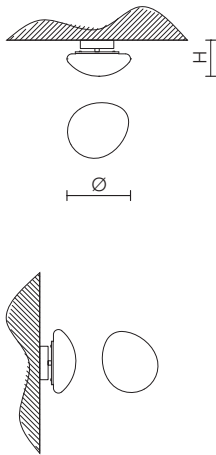

SASSO APL1

H 15 cm
6.00"

Ø 20 cm
7.90"

W 1x40w



SASSO APL7

H 15 cm
6.00"

Ø 65 cm
25.60"

W 7x40w



SASSO APL3

H 15 cm
6.00"

Ø 40 cm
15.80"

W 3x40w



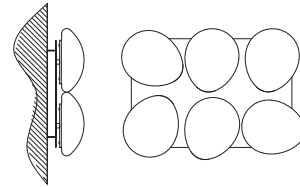
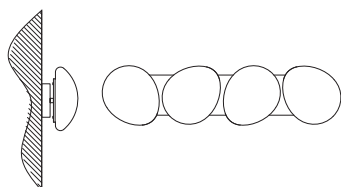
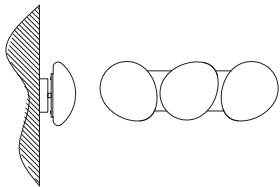
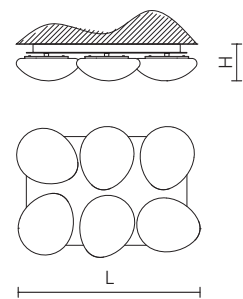
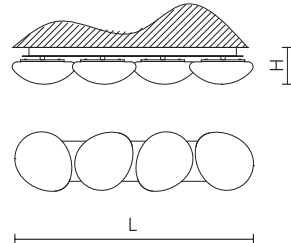
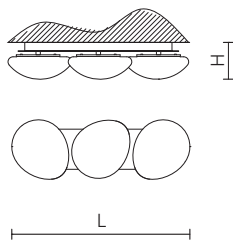

SASSO APL3 RC

H 15 cm
6.00"

L 55x20 cm
21.67x7.88"

W 3x40w



SASSO APL4 RC

H 15 cm
6.00"

L 75x20 cm
29.55x7.88"

W 4x40w



SASSO APL6 RC

H 15 cm
6.00"

L 55x40 cm
21.67x15.76"

W 6x40w







DECÒ

Design by: CAMBI, SCATENA, TURINI



Decò S2 90





LIGHT OFF



LIGHT ON







Decò APL1 60



Decò APL1 45



Decò APL1 60



Decò STL4 60



Decò STL4 60



Decò TL1 45

Decò TL1 60



DECÒ

Design by: CAMBI, SCATENA, TURINI

Lampada con struttura in alluminio laccato e diffusore in policarbonato decorato.

4 varianti colore: bianco opaco, nero lucido, rosso porpora, foglia argento.

Lamp with lacquered aluminium frame and decorated polycarbonate diffuser.

4 different colours: opaque white, jet black, purple red, silver leaf

Lampe mit lackierter Aluminiumstruktur und Diffusor aus verziertem Polycarbonat.

4 Farbvarianten: Weiß matt, Schwarz glänzend, Purpurrot, Blattsilber.

Lampe avec une structure en aluminium laqué et diffuseur en polycarbonate décoré.

4 variantes de couleur: blanc mat, noir brillant, rouge pourpre, feuille argent.

Lámpara con estructura de aluminio lacado y difusor de policarbonato decorado.

4 variantes en color: blanco opaco, negro brillante, rojo púrpura, hoja de plata.

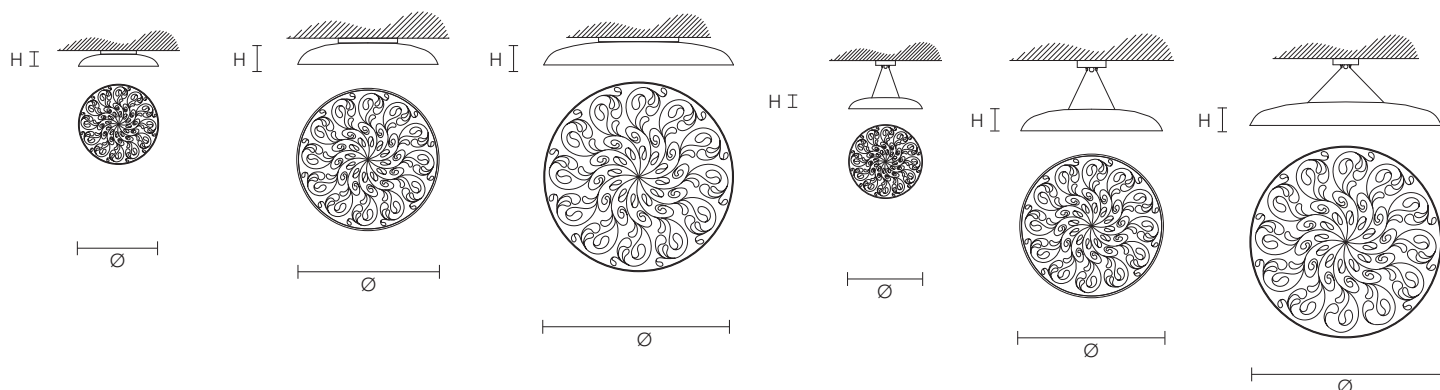

DECÒ APL1 45

H 10 cm
3.95"

Ø 45 cm
17.75"

W 1x22w

1xTR5 2Gx13
Fluorescenza

DECÒ APL1 60

H 12 cm
4.75"

Ø 60 cm
23.65"

W 1x40w

1xTR5 2Gx13
Fluorescenza

DECÒ APL2 90

H 14 cm
5.50"

Ø 90 cm
35.45"

W 1x22w
1x40w

2xTR5 2Gx13
Fluorescenza

DECÒ S1 45

H 7 cm
2.75"

Ø 45 cm
17.75"

W 1x22w

1xTR5 2Gx13
Fluorescenza

DECÒ S1 60

H 9 cm
3.55"

Ø 60 cm
23.65"

W 1x40w

1xTR5 2Gx13
Fluorescenza

DECÒ S2 90

H 11 cm
4.35"

Ø 90 cm
35.45"

W 1x22w
1x40w

2xTR5 2Gx13
Fluorescenza



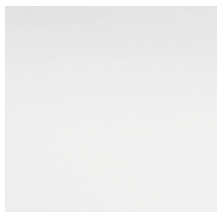

WH-M
Bianco opaco



BK-S
Nero lucido

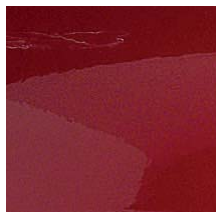

REP-S
Rosso porpora



SL-L
Foglia argento

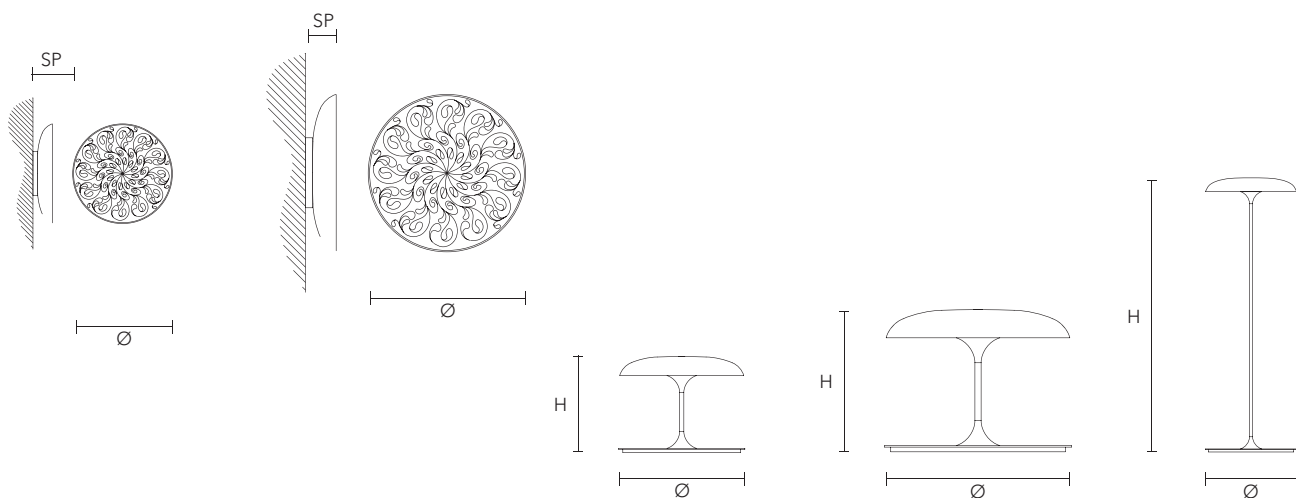

DECÒ APL1 45

SP 10 cm
3.95"

Ø 45 cm
17.75"

W 1x22w



1xTR5 2Gx13
Fluorescenza



DECÒ APL1 60

SP 12 cm
4.75"

Ø 60 cm
23.65"

W 1x40w



1xTR5 2Gx13
Fluorescenza



DECÒ TL1 45

H 35 cm
13.80"

Ø 45 cm
17.75"

W 1x22w



1xTR5 2Gx13
Fluorescenza



DECÒ TL1 60

H 40 cm
15.75"

Ø 60 cm
23.65"

W 1x40w



1xTR5 2Gx13
Fluorescenza



DECÒ STL4 60

H 185 cm
72.85"

Ø 60 cm
23.65"

W 4x60w

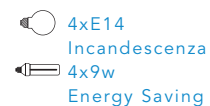

4xE14
Incandescenza
4x9w
Energy Saving



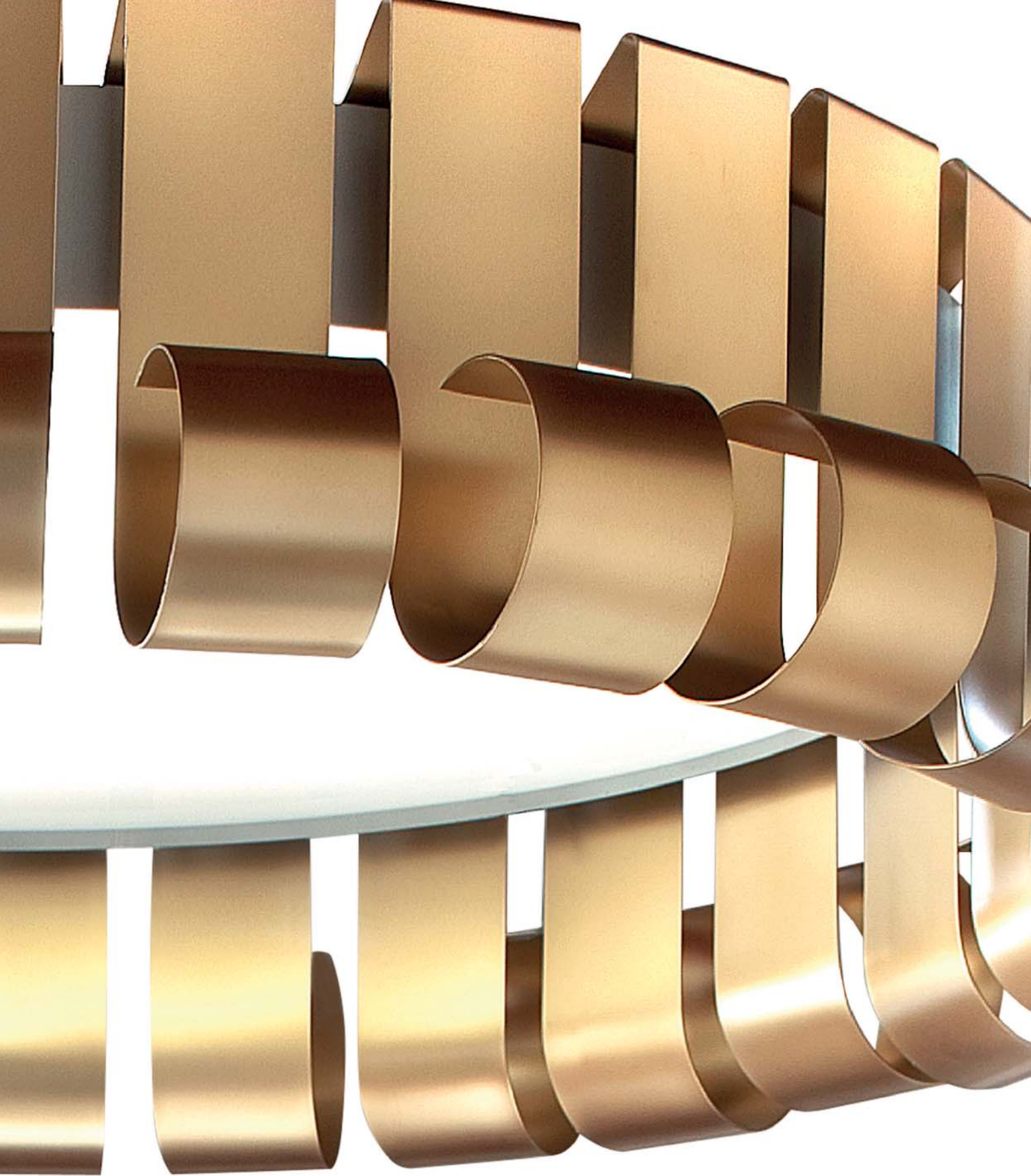



DORÉ

Design by: CAMBI,SCATENA,TURINI



Dorè STL1



Dorè S2 90

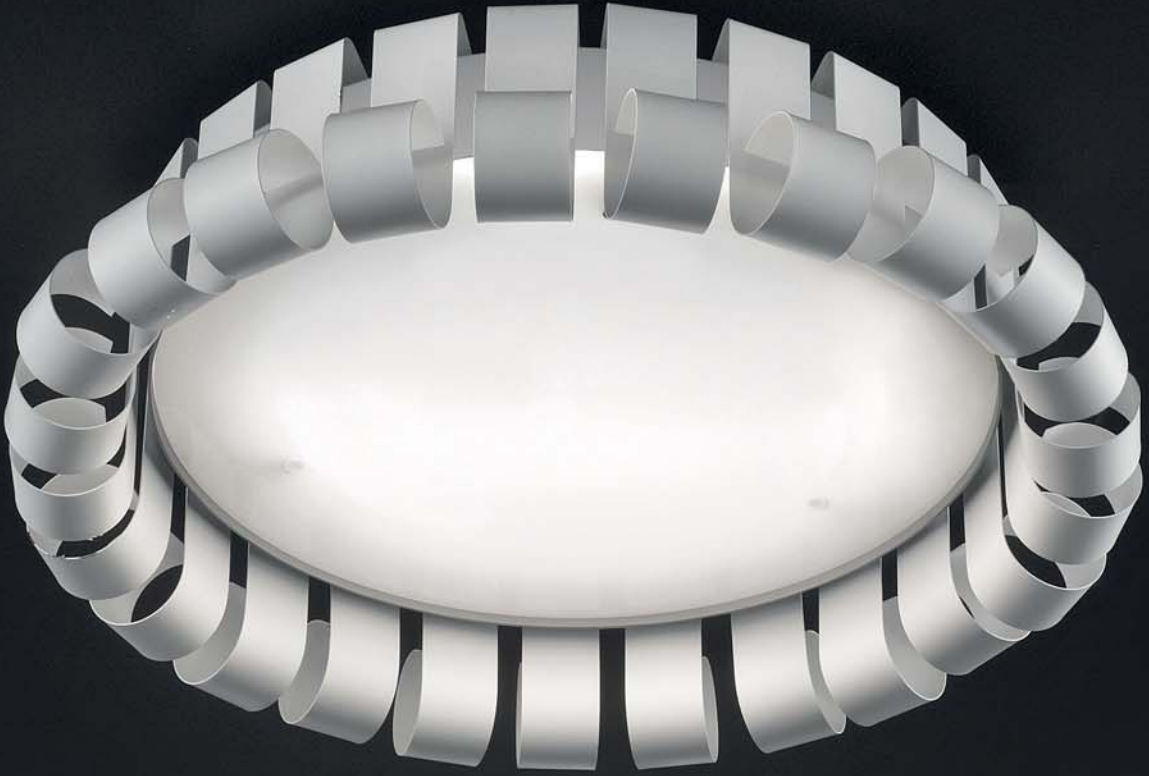

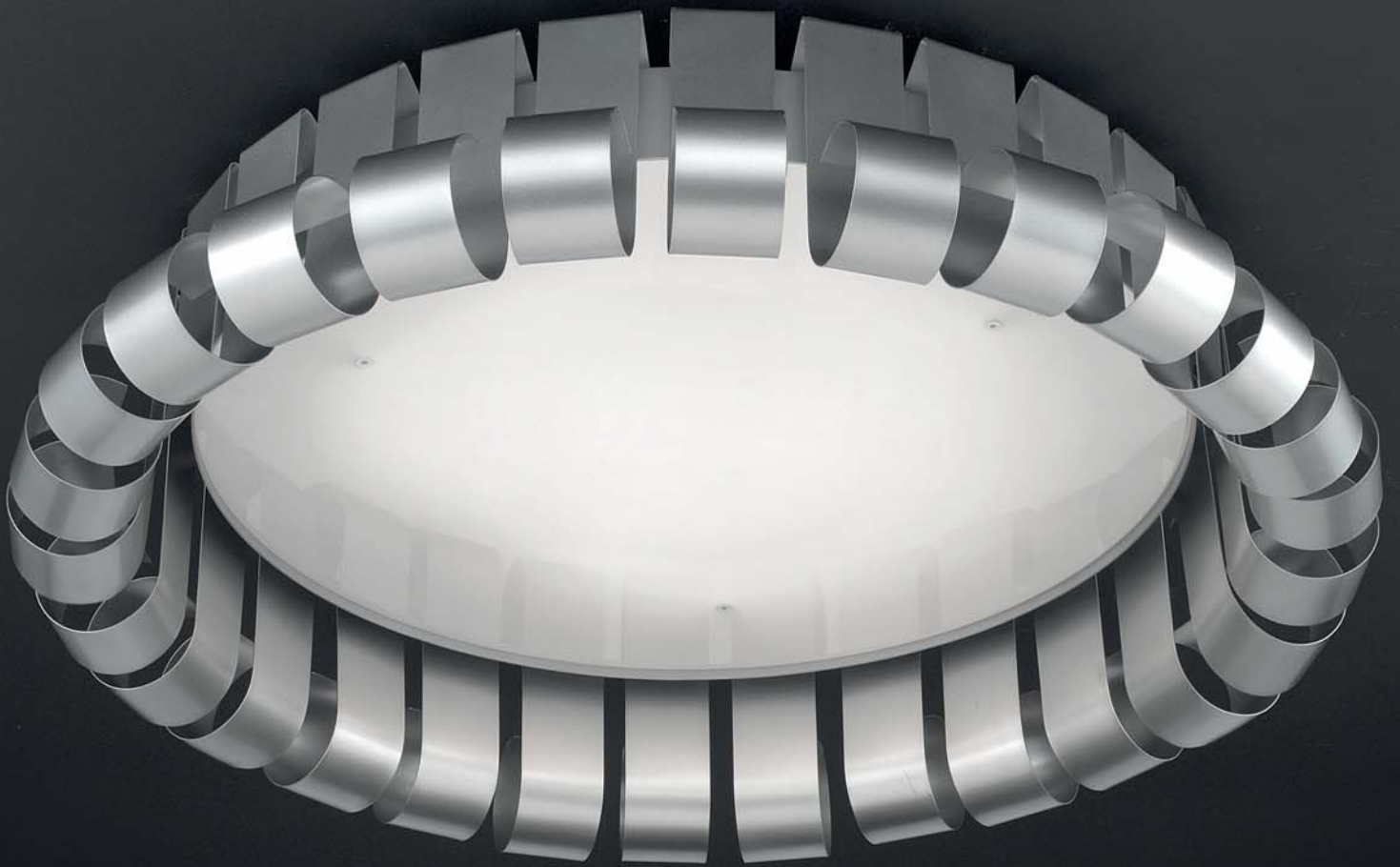



Dorè TL1 50



Dorè A1 45

DORÉ

Design by: CAMBI, SCATENA, TURINI

Lampada con struttura e decori in metallo verniciato e diffusore in policarbonato bianco latte .

Lamp with enamelled metal frame and decoration and milk-white polycarbonate shade.

Lampe mit Struktur und Verzierungen aus lackiertem Metall und Diffusor aus milchweißem Polycarbonat.

Lampe avec structure et décorations en métal verni et diffuseur en polycarbonate blanc lait.

Lámpara con estructura y decoraciones de metal pintado y difusor de policarbonato blanco leche.

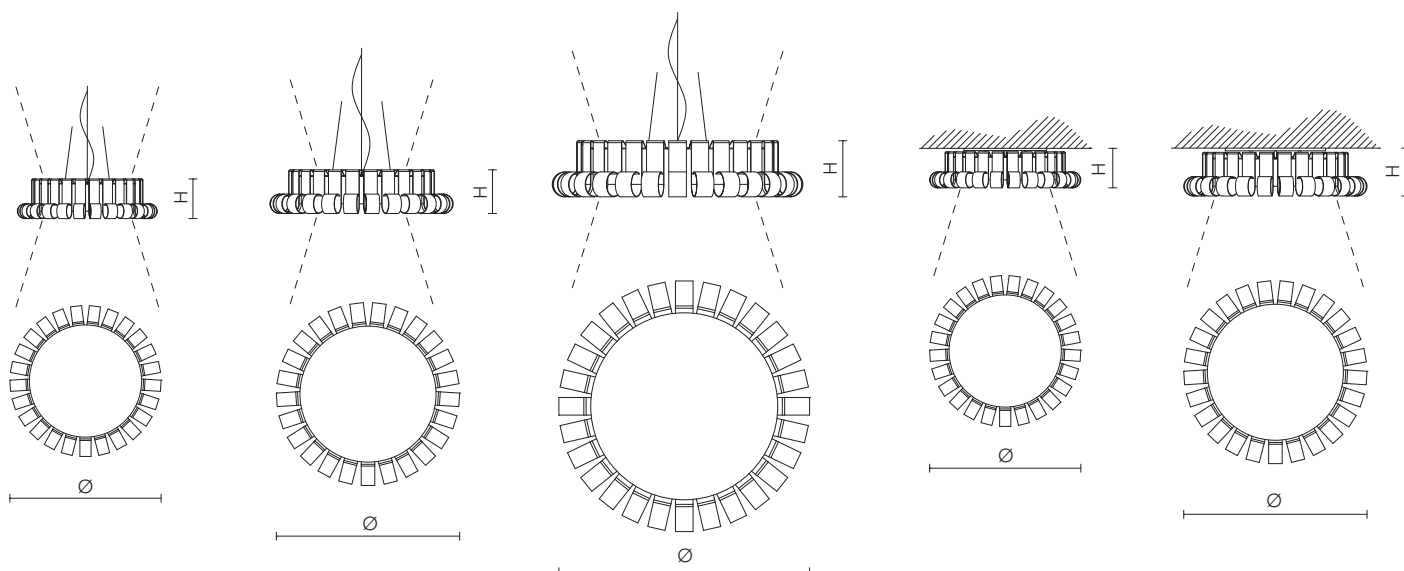

DORÉ S1 50

H 17 cm
6.70"

∅ 50 cm
19.70"

W 1x22w



DORÉ S2 70

H 17 cm
6.70"

∅ 70 cm
27.60"

W 1x22W
1x40W



DORÉ S2 90

H 21 cm
8.3"

∅ 95 cm
37.50"

W 1x22W
1x40W



DORÉ PL1 50

H 50 cm
19.70"

∅ 50 cm
19.70"

W 1x22W



DORÉ PL2 70

H 19 cm
7.50"

∅ 70 cm
27.60"

W 1x22W
1x40W





WH-M
Bianco opaco



CR-M
Nickel opaco



GD-M
Oro opaco

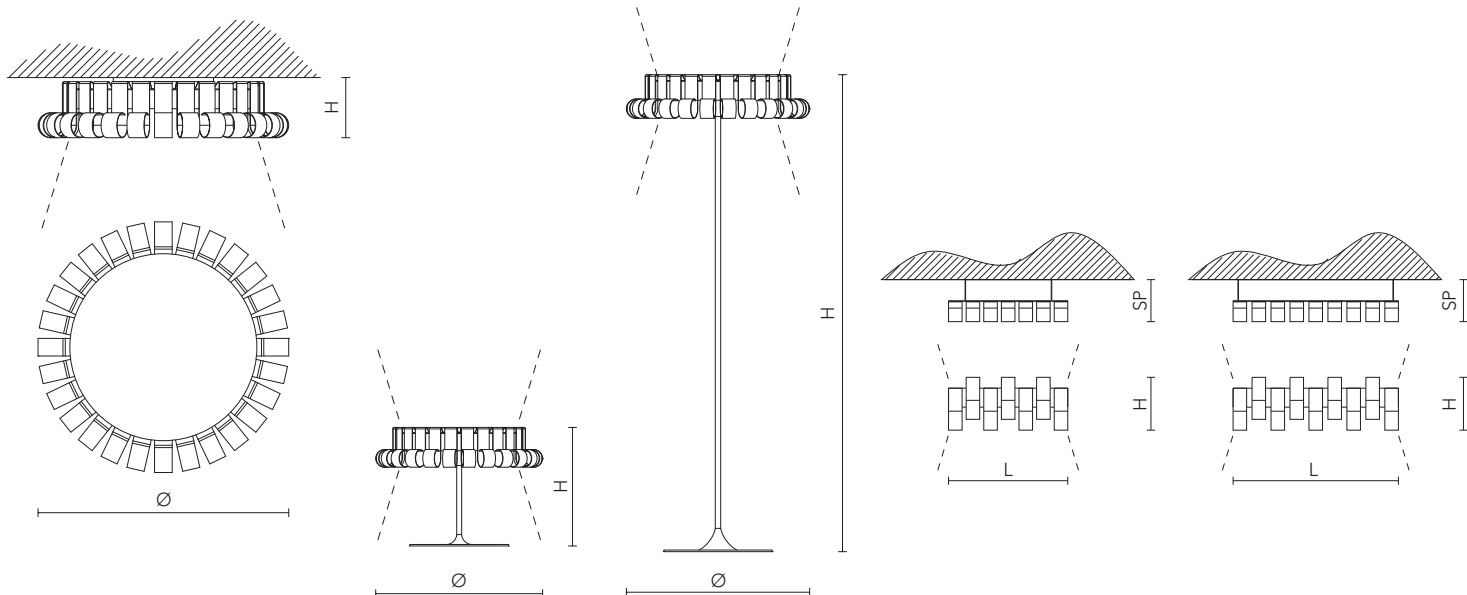

DORÉ PL2 90

H 23 cm
9.10"

Ø 90 cm
35.50

W 1x22W
1x40W



DORÉ TL1 50

H 50 cm
19.70"

Ø 50 cm
19.70"

W 1x22W



DORÉ STL1

H 180 cm
70.90"

Ø 70 cm
27.60"

W 1x20W



DORÉ A1 45

H 20 cm
7.90"

L 45 cm
27.60"

SP 16 cm
6.30"

W 1x18W



DORÉ A1 60

H 20 cm
7.90"

L 61 cm
24.10"

SP 16 cm
6.30"

W 1x36w





EVA

Design by: Fly Design Studio



Eva TL3+1G





Eva TL3+1G

Eva TL1P



Eva A3



Eva TL1 M

Eva A1



Eva S10



MASIERO



HIGH

MASIERO

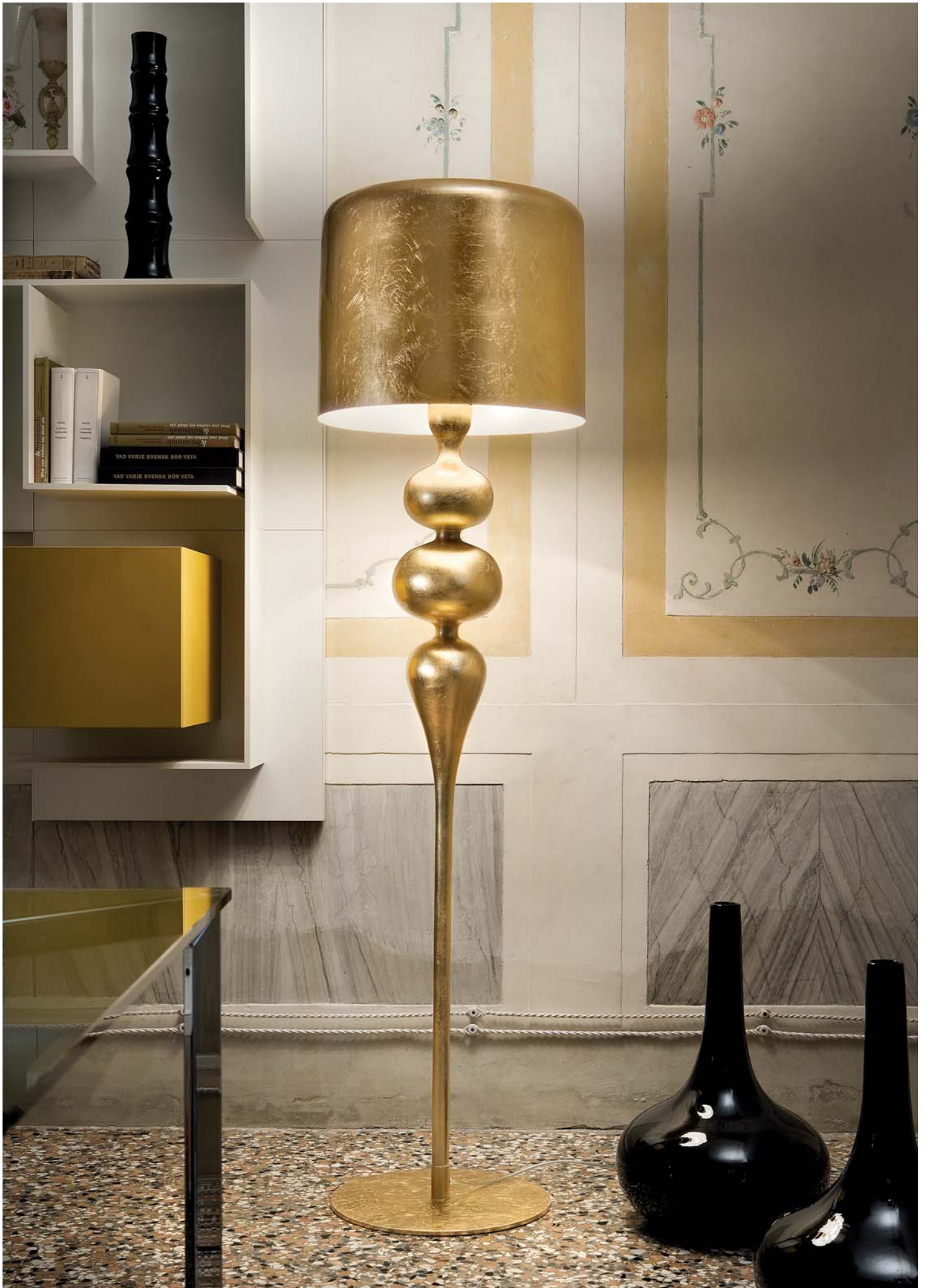

Eva STL 3+1



Eva S3+1

EVA

Design by: Fly Design Studio

Lampada con struttura in resina e poliuretano laccati, paralumi in alluminio verniciato.

Lamp with turned wooden frame, lamp shades from laquered aluminium.

Lampe mit gedrehter Holzstruktur, Lampenschirme aus lackiertem Aluminium

Lampe avec structure en bois tournée, abat-jour en aluminium verni.

Lámpara con estructura de madera torneada, pantallas de aluminio barnizado.

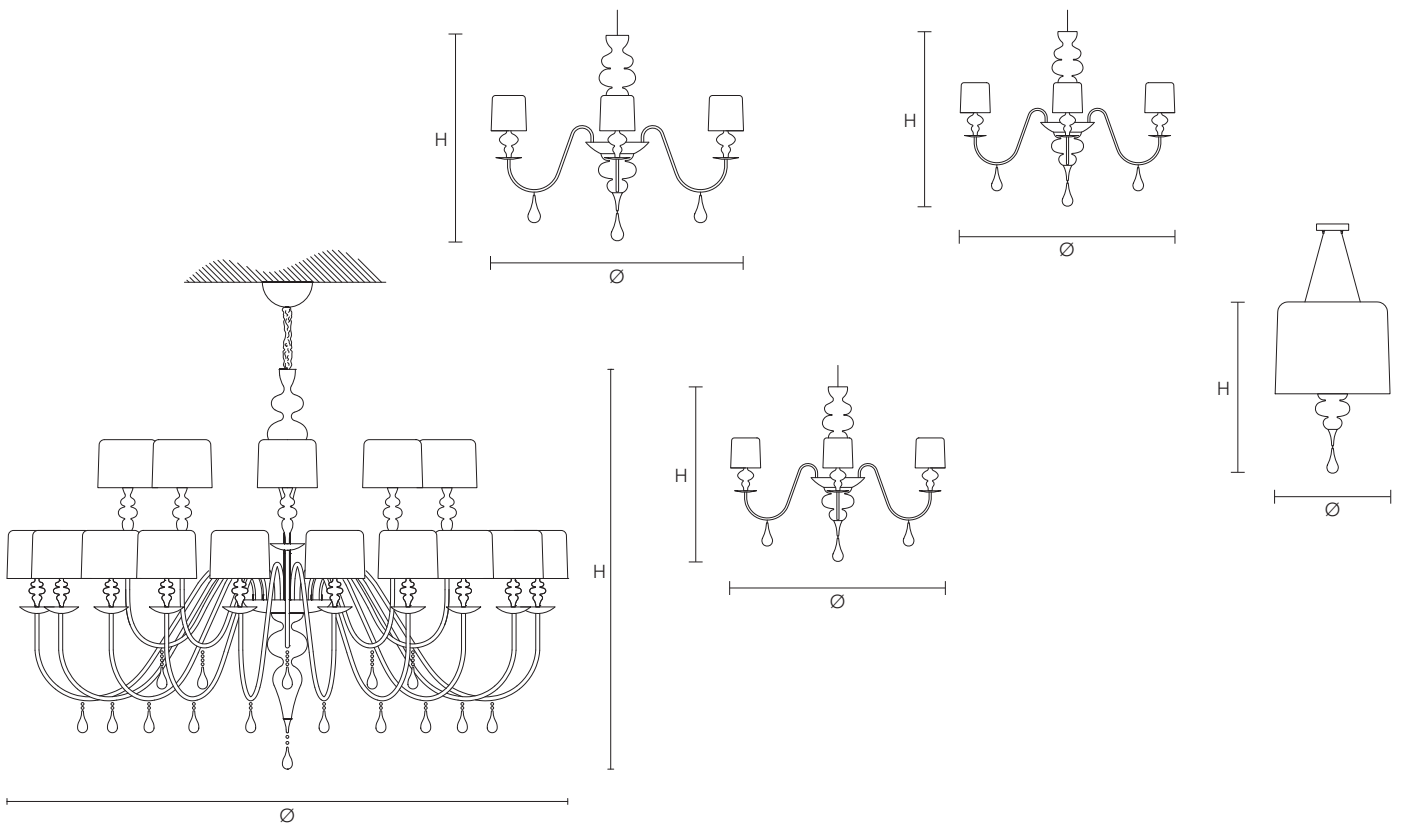

EVA S20+10

H 200 cm
78.80"

Ø 280 cm
110.50"

W 30x60w

30xE14
Incandescenza
30x9w
Energy saving



EVA S10

H 75 cm
29.60"

Ø 110 cm
43.40"

W 10x60w

10xE14
Incandescenza
10x9w
Energy saving



EVA S8

H 75 cm
29.60"

Ø 90 cm
35.50"

W 8x60w

8xE14
Incandescenza
8x9w
Energy saving



EVA S5

H 60 cm
23.65"

Ø 70 cm
27.60"

W 5x60w

5xE14
Incandescenza
5x9w
Energy saving



EVA S3+1

H 75 cm
29.60"

Ø 50 cm
19.70"

W 3x100w E27
1x150w R7S

3xE27
Incandescenza
1xR7S





Foglia argento



Foglia oro



Bianco opaco

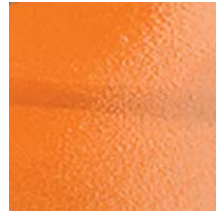

Arancio lucido



Magenta lucido



Nero lucido

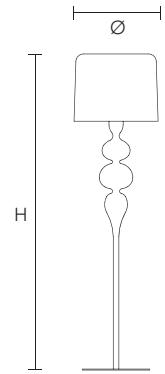
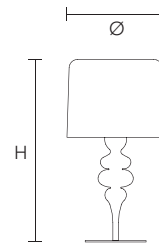
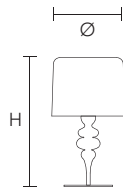
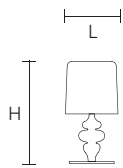
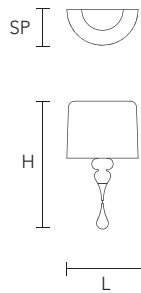
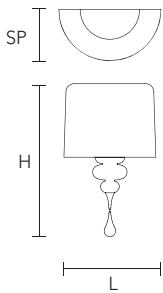

EVA A3

H 70 cm
27.60"

L 40 cm
15.80"

SP 20 cm
7.90"

W 3x100w

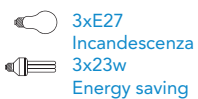

EVA A1 M

H 54 cm
21.30"

L 30cm
11.90"

SP 15 cm
6.00"

W 1x100w

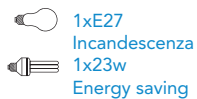

EVA TL1P

H 28 cm
11.10"

Ø 14 cm
5.60"

W 1x60w

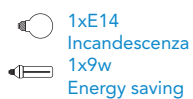

EVA TL1M

H 53 cm
21.00"

Ø 30 cm
11.90"

W 1x100w

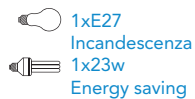

EVA TL3+1G

H 75 cm
29.60"

Ø 40 cm
15.80"

W 3x100w E27
1x150w R7S

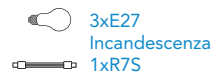

EVA STL3+1

H 190 cm
74.90"

Ø 50 cm
19.70"

W 3x100w E27
1x150w R7S

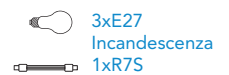





ARTè

Design by: Manuel Vivian



Artè S4 RC





Artè A1 70

Artè A1 45



Artè S4 SQ





Artè APL4 RC

ARTè

Design by: Manuel Vivian

Lampada con struttura in poliuretano laccato e diffusore in policarbonato bianco latte.

4 varianti colore: bianco opaco, nero lucido, verde felce lucido, rosso bruno lucido.

Lamp with lacquered polyurethane frame and white polycarbonate diffuser.

4 different colours: opaque white, jet black, bright fern green, dark bright red.

Lampe mit lackierter Polyurethanstruktur und Diffusor aus milchweißem Polycarbonat.

4 Farbvarianten: Weiß matt, Schwarz glänzend, Farngrün glänzend, Rotbraun glänzend.

Lampe avec une structure en polyuréthane laqué et diffuseur en polycarbonate blanc lait.

4 variantes de couleur: blanc mat, noir brillant, vert fougère brillant, rouge brun brillant.

Lámpara con estructura de poliuretano lacado y difusor de policarbonato blanco leche.

4 variantes en color: blanco opaco, negro brillante, verde helecho brillante, rojo oscuro brillante.

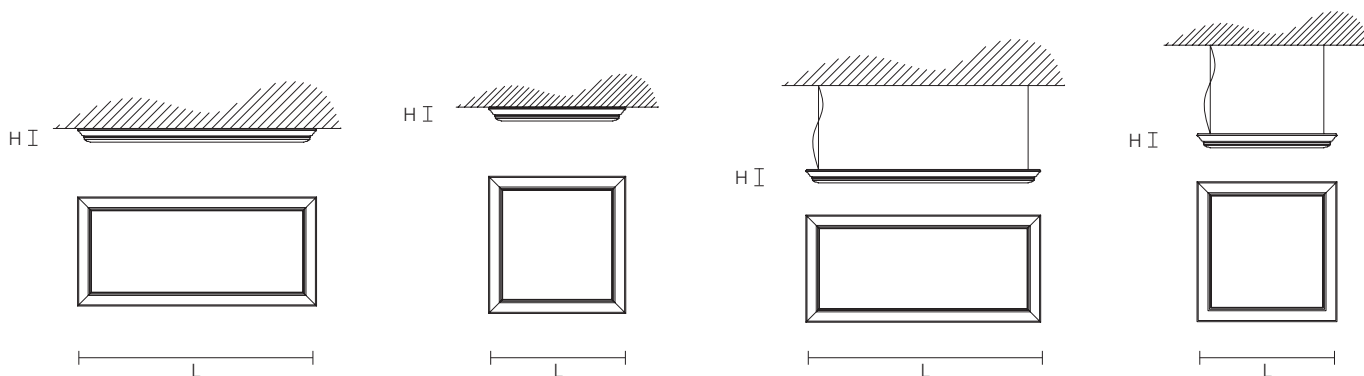

ARTè APL4 RC

H 8 cm
3.15"

L 138x63 cm
54.30"x24.80"

W 4x54w



ARTè APL4 SQ

H 8 cm
3.15"

L 78x78 cm
30.70"x30.70"

W 4x24w



ARTè S4 RC

H 8 cm
3.15"

L 138x63 cm
54.30"x24.80"

W 4x54w



ARTè S4 SQ

H 8 cm
3.15"

L 78x78 cm
30.70"x30.70"

W 4x24w





WH-M
Bianco opaco



BK-S
Nero lucido



GRF-S
Verde felce
lucido



REB-S
Rosso bruno
lucido

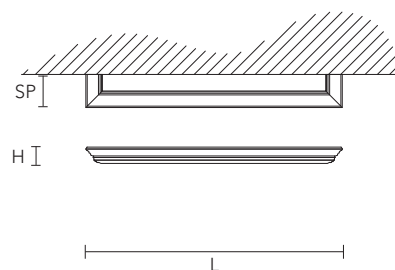
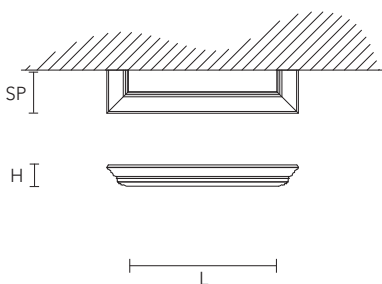
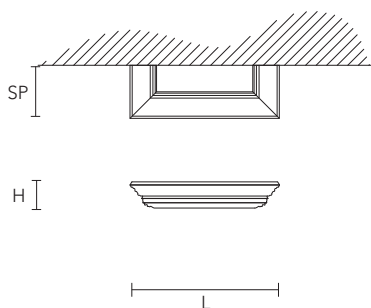

ARTè A1 45

H 8 cm
3.15"

L 45 cm
17.70"

SP 16 cm
6.30"

W 1x18w

 1xTCL-2G11
Fluorescenza



ARTè A1 70

H 8 cm
3.15"

L 71 cm
27.95"

SP 16 cm
6.30"

W 1x36w

 1xTCL-2G11
Fluorescenza



ARTè A2 124

H 8 cm
3.15"

L 124 cm
48.80"

SP 16 cm
6.30"

W 2x36w

 2xTCL-2G11
Fluorescenza



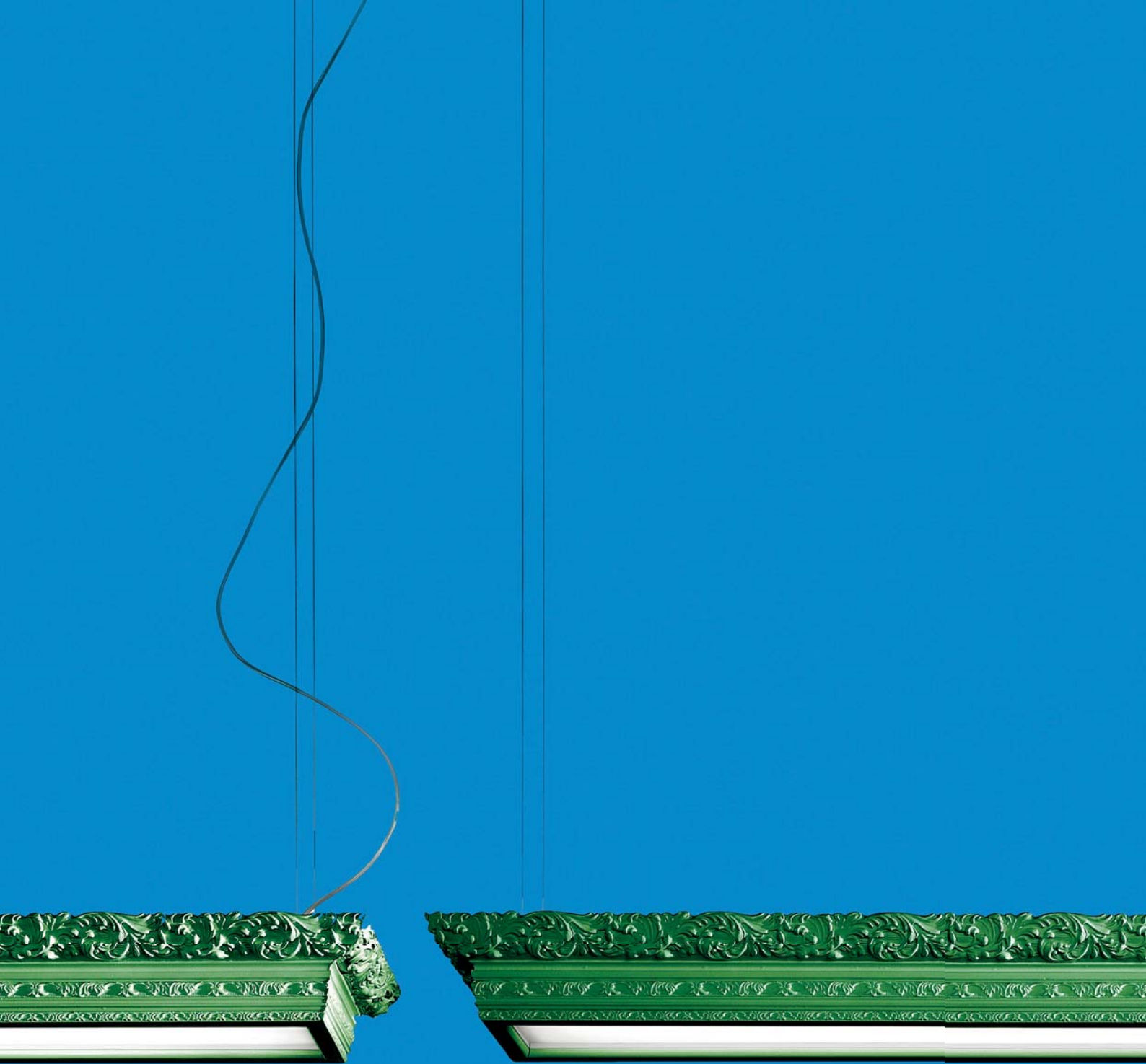

ARTè linear

Design by Manuel Vivian





Artè Linear S1





Artè Linear APL1

ARTè linear

Design by: Manuel Vivian

Lampada con struttura in poliuretano laccato e diffusore in policarbonato bianco latte.

4 varianti colore: bianco opaco, nero lucido, verde felce lucido, rosso bruno lucido.

Lamp with lacquered polyurethane frame and white polycarbonate diffuser.

4 different colours: opaque white, jet black, bright fern green, dark bright red.

Lampe mit lackierter Polyurethanstruktur und Diffusor aus milchweißem Polycarbonat.

4 Farbvarianten: Weiß matt, Schwarz glänzend, Farngrün glänzend, Rotbraun glänzend.

Lampe avec une structure en polyuréthane laqué et diffuseur en polycarbonate blanc lait.

4 variantes de couleur: blanc mat, noir brillant, vert fougère brillant, rouge brun brillant.

Lámpara con estructura de poliuretano lacado y difusor de policarbonato blanco leche.

4 variantes en color: blanco opaco, negro brillante, verde helecho brillante, rojo oscuro brillante.



WH-M
Bianco opaco



BK-S
Nero lucido



GRF-S
Verde felce lucido



REB-S
Rosso bruno lucido

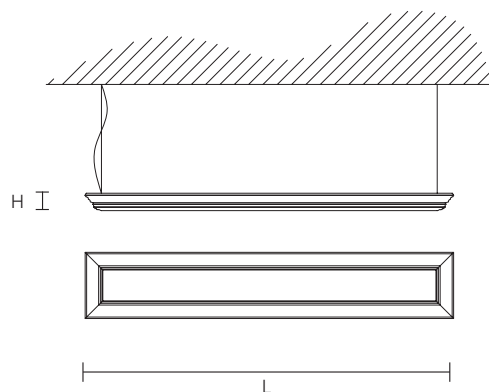
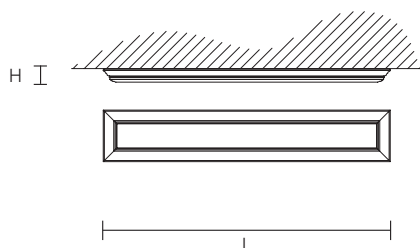

ARTè LINEAR APL1

H 12 cm
4.75"

L 167 cm
65.75"

SP 30 cm
11.80"

W 1x80w



ARTè LINEAR S1

H 12 cm
4.75"

L 167 cm
65.75"

SP 30 cm
11.80"

W 1x80w

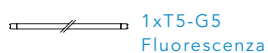





OLÀ

Design by: Fly Design Studio



Olà S6 90







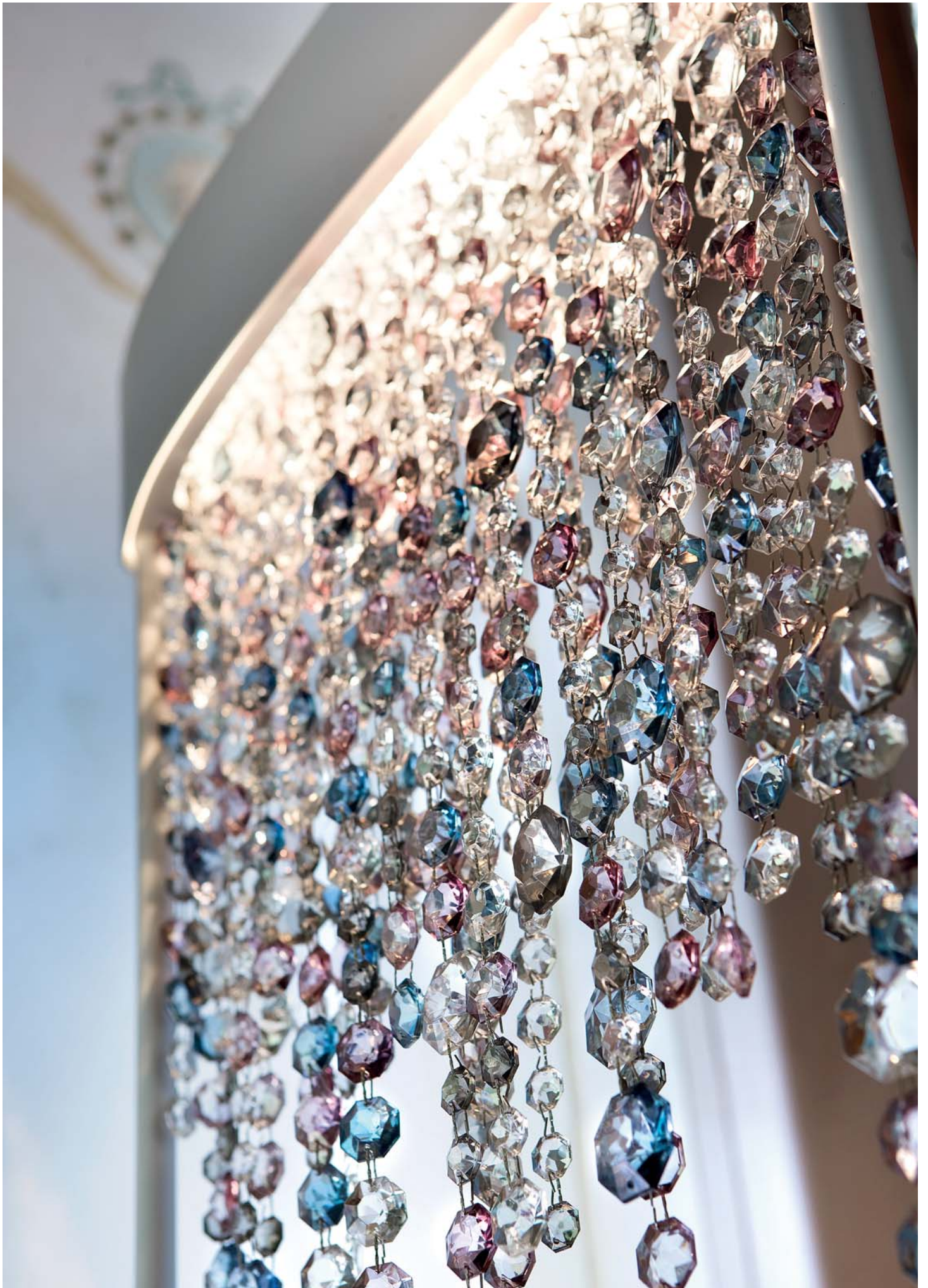



Olà STL 2

Olà TL 2



Olà A6 OV 160

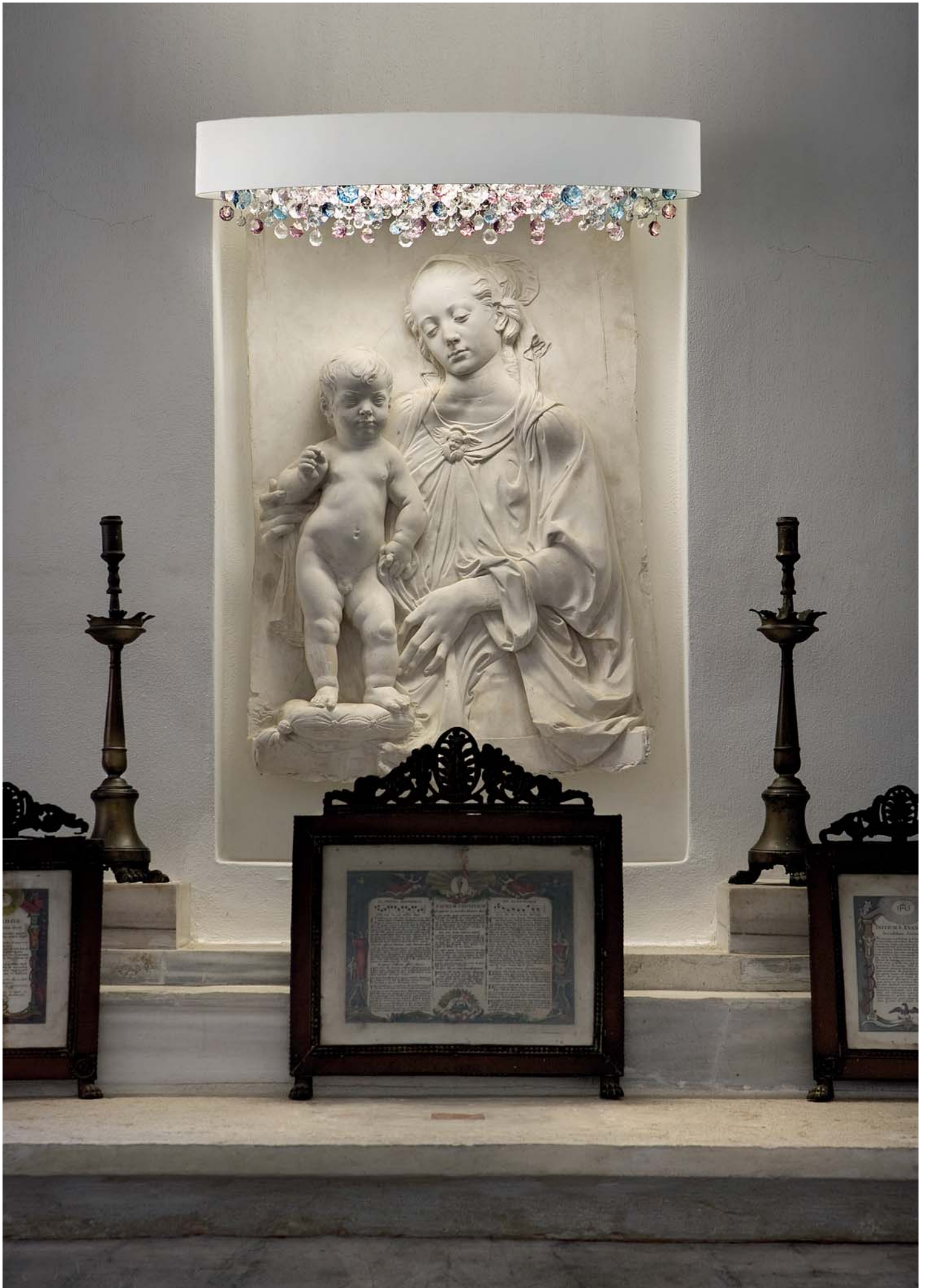

Olà A2 OV 70

OLÀ

Design by: Fly Design Studio

Lampada con struttura in metallo verniciato, pendagli in vetro italiano verniciato.

Powder coated metal frame, coated Italian-glass pendants.

Lampe mit lackierter Metallstruktur, Gehänge aus lackiertem italienischem Glas.

Lampe avec structure en métal verni, breloques en verre italien verni.

Lámpara con estructura de metal barnizado, colgantes de vidrio Italiano barnizado.

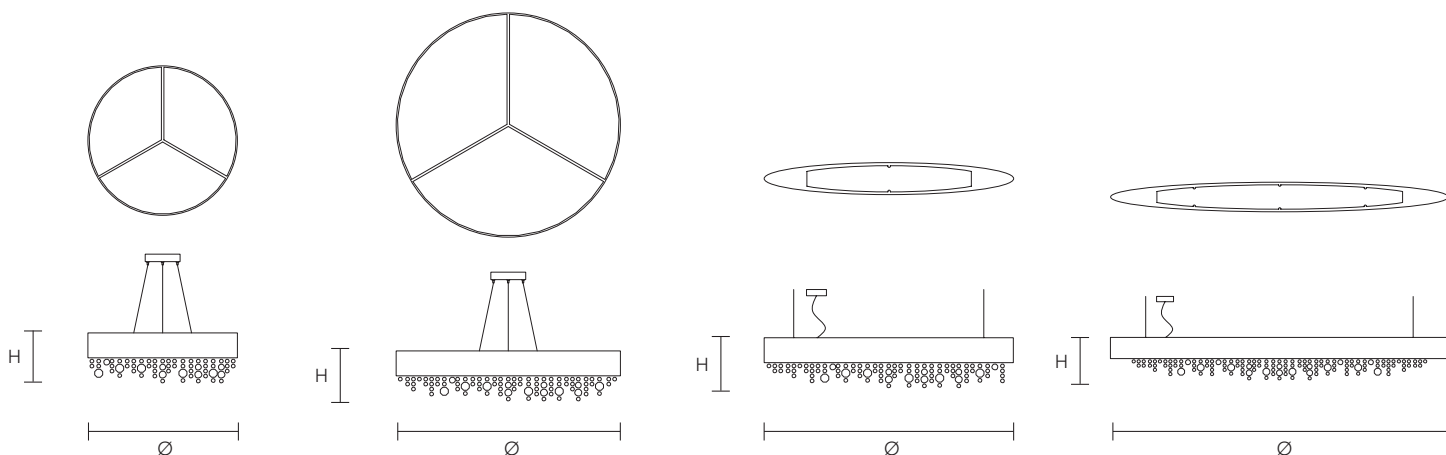

OLÀ S6 60

H 20 cm
7.90"

Ø 60 cm
23.70"

W 12x60w



OLÀ S6 90

H 20 cm
7.90"

Ø 90 cm
35.50"

W 12x60w



OLÀ S4 OV 100

H 20 cm
7.90"

Ø 100x13 cm
39.40x5.10"

W 8x60w



OLÀ S6 OV 160

H 20 cm
7.90"

Ø 160x14 cm
63.00x5.50"

W 10x60w





Bianco opaco



Bronzo opaco

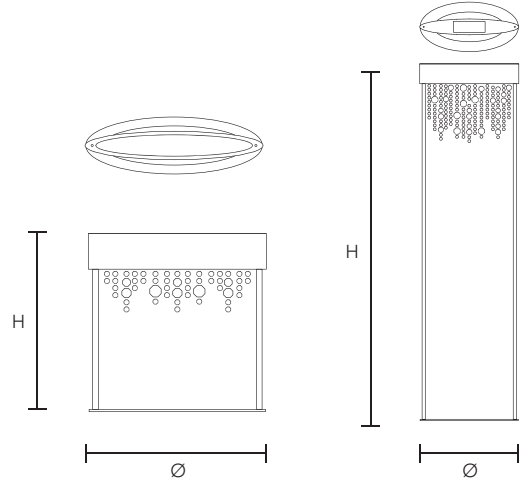
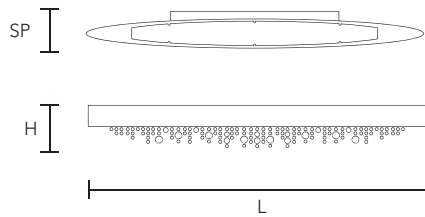
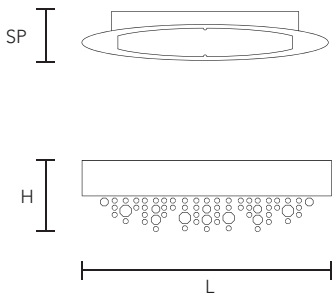

OLÀ A2 OV 70

H 20 cm
7.90"

L 70 cm
11.82"

SP 15 cm
6.00"

W 4x60w



OLÀ A6 OV 160

H 20 cm
7.90"

L 160 cm
63.00"

SP 20
7.90"

W 10x60w



OLÀ TL2

H 50 cm
19.70"

Ø 50 cm
19.70"

W 4x60w



OLÀ STL2

H 180 cm
70.90"

Ø 50 cm
19.70"

W 4x60w







TESSUTI

Design by: Studio Stile Masiero



Round A1



Round S4 90

ROUND

Design by: Studio Stile Masiero

Strutture metalliche dalle molteplici forme sono elegantemente ricoperte da preziosi tessuti.

Different shaped, metallic structures are elegantly covered in precious fabrics.

Metallstrukturen in unterschiedlichsten Formen werden elegant von kostbaren Geweben überzogen.

Structures métalliques aux formes différentes recouvertes d'une façon élégante de précieux tissus.

Estructuras metálicas de múltiples formas son recubiertas elegantemente de preciados tejidos.

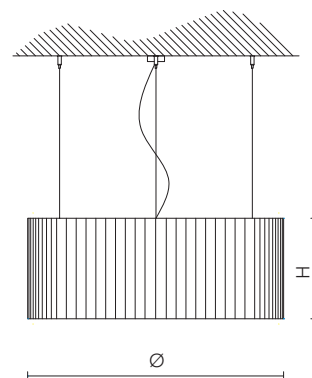
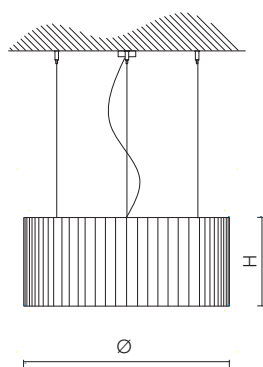
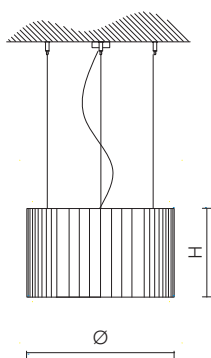
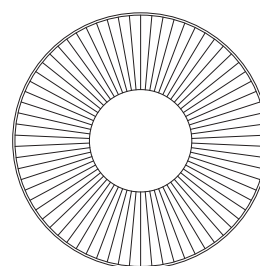
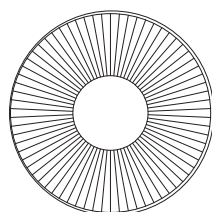
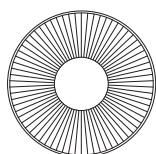

ROUND S1 50

H 30 cm
11.90"

Ø 50 cm
19.70"

W 1x60w

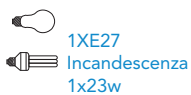

ROUND S2 70

H 30 cm
11.90"

Ø 70 cm
27.60"

W 2x60w

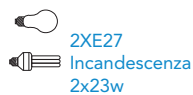

ROUND S4 90

H 30 cm
11.90"

Ø 90 cm
35.50"

W 4x60w

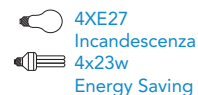

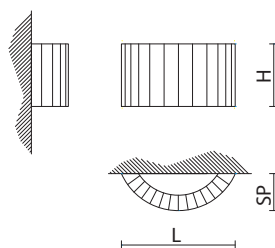
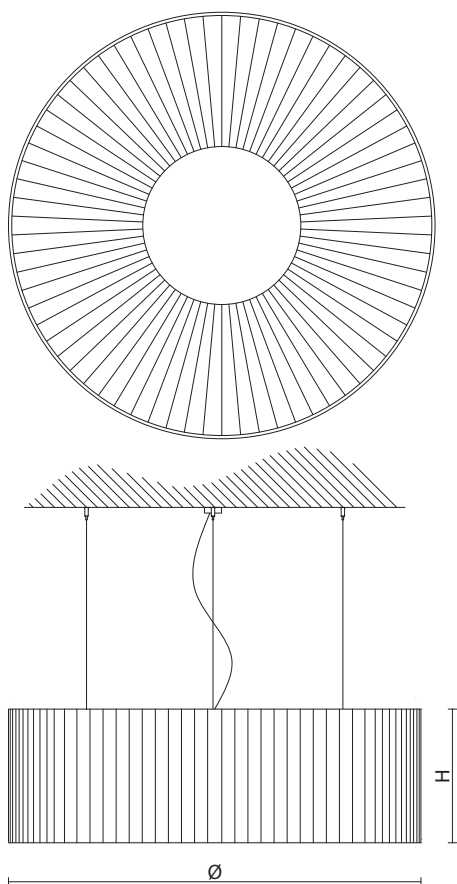

ROUND S6 150

H 45 cm
17.80"

Ø 150 cm
59.10"

W 6x60w

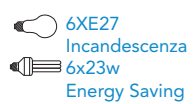

ROUND A1

H 21 cm
8.30"

Ø 40 cm
15.80"

SP 13 cm
5.20"

W 1x40w

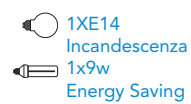



Cone S3 60



Cone A2



Cone S2 40

CONE

Design by: Studio Stile Masiero

Strutture metalliche dalle molteplici forme sono elegantemente ricoperte da preziosi tessuti.

Different shaped, metallic structures are elegantly covered in precious fabrics.

Metallstrukturen in unterschiedlichsten Formen werden elegant von kostbaren Geweben überzogen.

Structures métalliques aux formes différentes recouvertes d'une façon élégante de précieux tissus.

Estructuras metálicas de múltiples formas son recubiertas elegantemente de preciados tejidos.

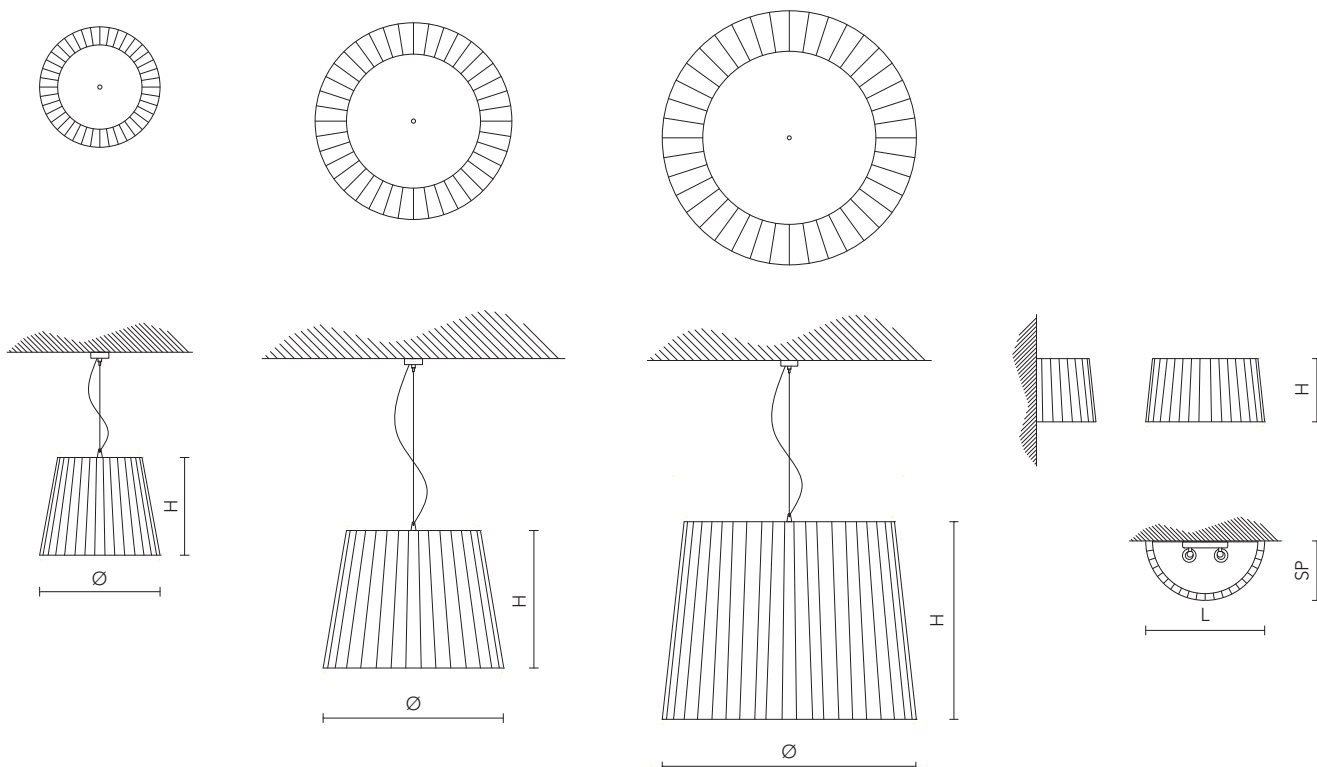

CONE S2 40

H 30 cm
11.90"

Ø 40 cm
15.80"

W 2x60w

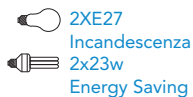

CONE S3 60

H 45 cm
17.80"

Ø 60 cm
23.70"

W 3x60w

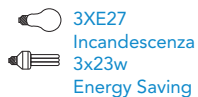

CONE S3 90

H 70 cm
27.55"

Ø 90 cm
35.45"

W 3x60w

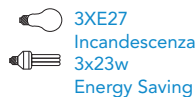

CONE A2

H 21 cm
8.30"

Ø 40 cm
15.80"

SP 20 cm
7.90"

W 2x40w

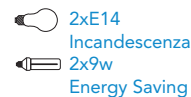



Dome A1



Dome S3 60



Dome S4 100





Dome S4 100

DOME

Design by: Studio Stile Masiero

Strutture metalliche dalle molteplici forme sono elegantemente ricoperte da preziosi tessuti.

Different shaped, metallic structures are elegantly covered in precious fabrics.

Metallstrukturen in unterschiedlichsten Formen werden elegant von kostbaren Geweben überzogen.

Structures métalliques aux formes différentes recouvertes d'une façon élégante de précieux tissus.

Estructuras metálicas de múltiples formas son recubiertas elegantemente de preciados tejidos.

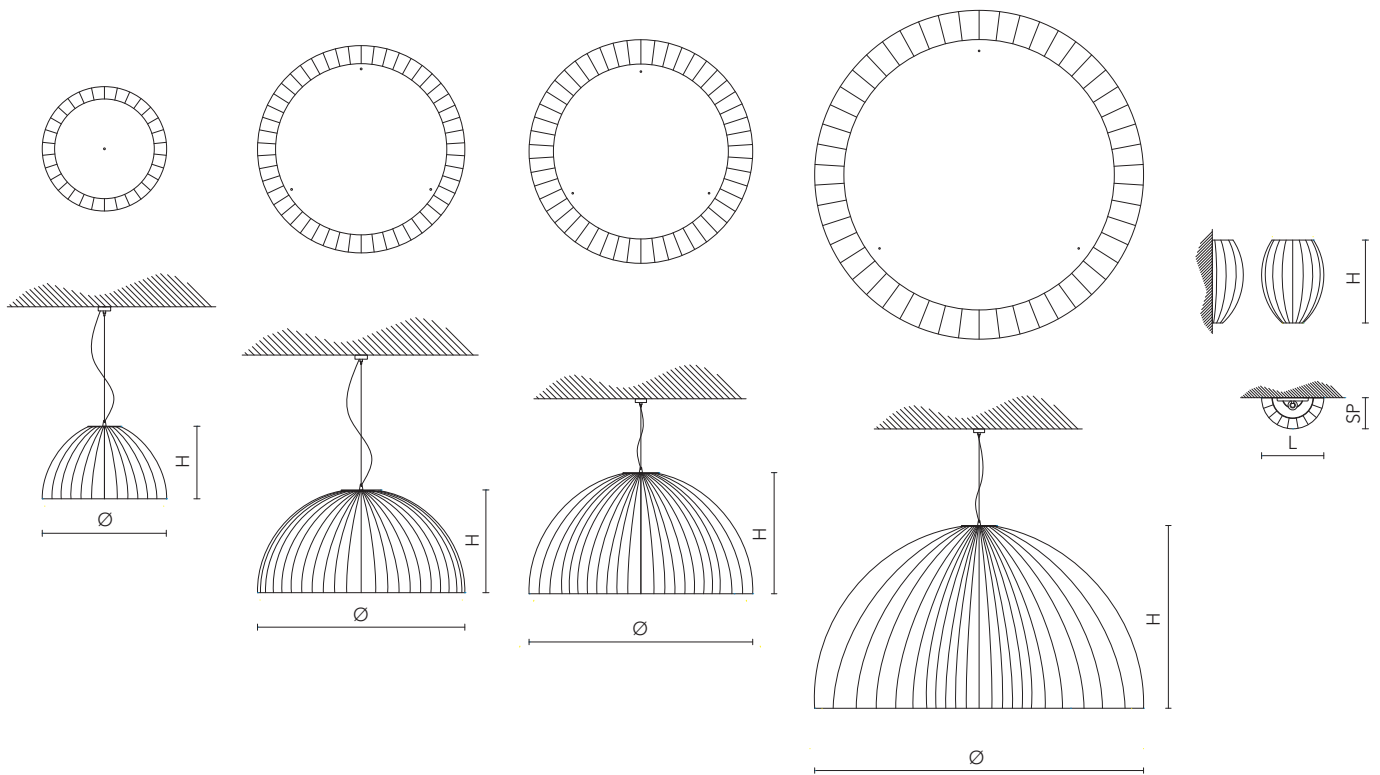

DOME S1 60

H 35 cm
13.80"

Ø 60 cm
23.70"

W 1x60w

1xE27
Incandescenza
1x23w
Energy Saving



DOME S3 100

H 55 cm
21.70"

Ø 100 cm
39.40"

W 3x60w

3xE27
Incandescenza
3x23w
Energy Saving



DOME S4 120

H 65 cm
25.60"

Ø 120 cm
47.25"

W 4x60w

4xE27
Incandescenza
4x23w
Energy Saving



DOME S5 180

H 100 cm
39.40"

Ø 180 cm
70.90"

W 5x60w

5xE27
Incandescenza
5x23w
Energy Saving



DOME A1

H 40 cm
15.80"

Ø 32 cm
12.60"

SP 17 cm
6.70"

W 1x40w

1xE14
Incandescenza
1x9w
Energy Saving





Oval S4 120





Oval S4 120

OVAL

Design by: Studio Stile Masiero

Strutture metalliche dalle molteplici forme sono elegantemente ricoperte da preziosi tessuti.

Different shaped, metallic structures are elegantly covered in precious fabrics.

Metallstrukturen in unterschiedlichsten Formen werden elegant von kostbaren Geweben überzogen.

Structures métalliques aux formes différentes recouvertes d'une façon élégante de précieux tissus.

Estructuras metálicas de múltiples formas son recubiertas elegantemente de preciados tejidos.

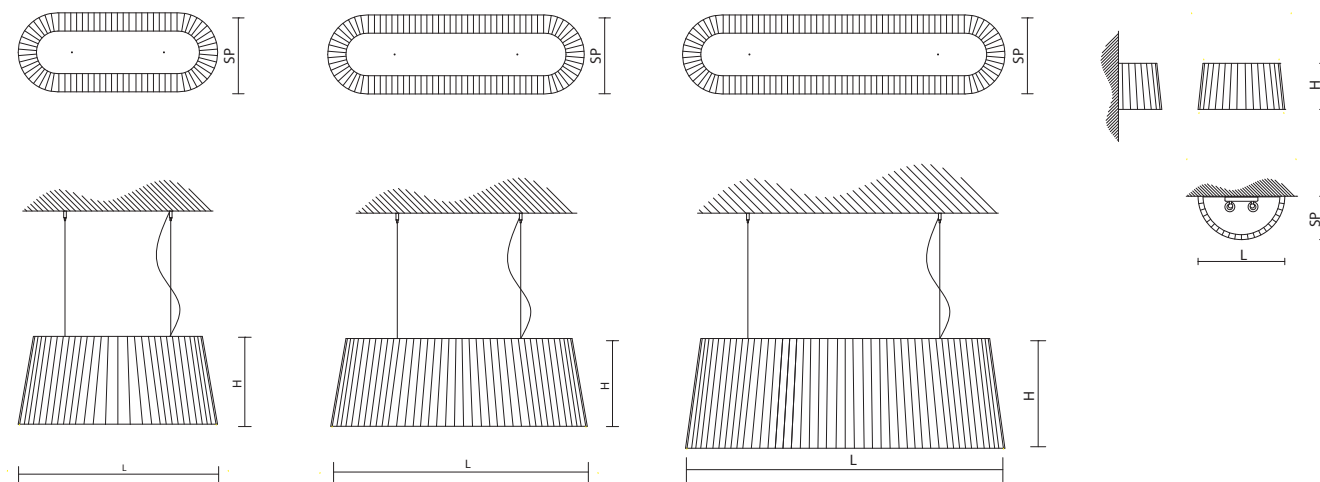

OVAL S2 90

H 40 cm
15.80"

L 90 cm
35.45"

SP 36 cm
14.20"

W 2x60w

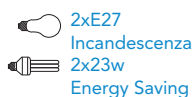

OVAL S4 120

H 40 cm
15.80"

L 120 cm
47.30"

SP 36 cm
14.20"

W 4x60w

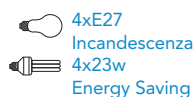

OVAL S5 150

H 50 cm
19.70"

L 150 cm
59.05"

SP 36 cm
14.20"

W 5x60w

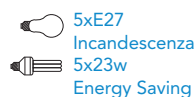

OVAL A2

H 21 cm
8.25"

L 40 cm
15.75"

SP 20 cm
7.90"

W 1x40w

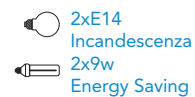



Square S4 100



Square S6 150



Square A2

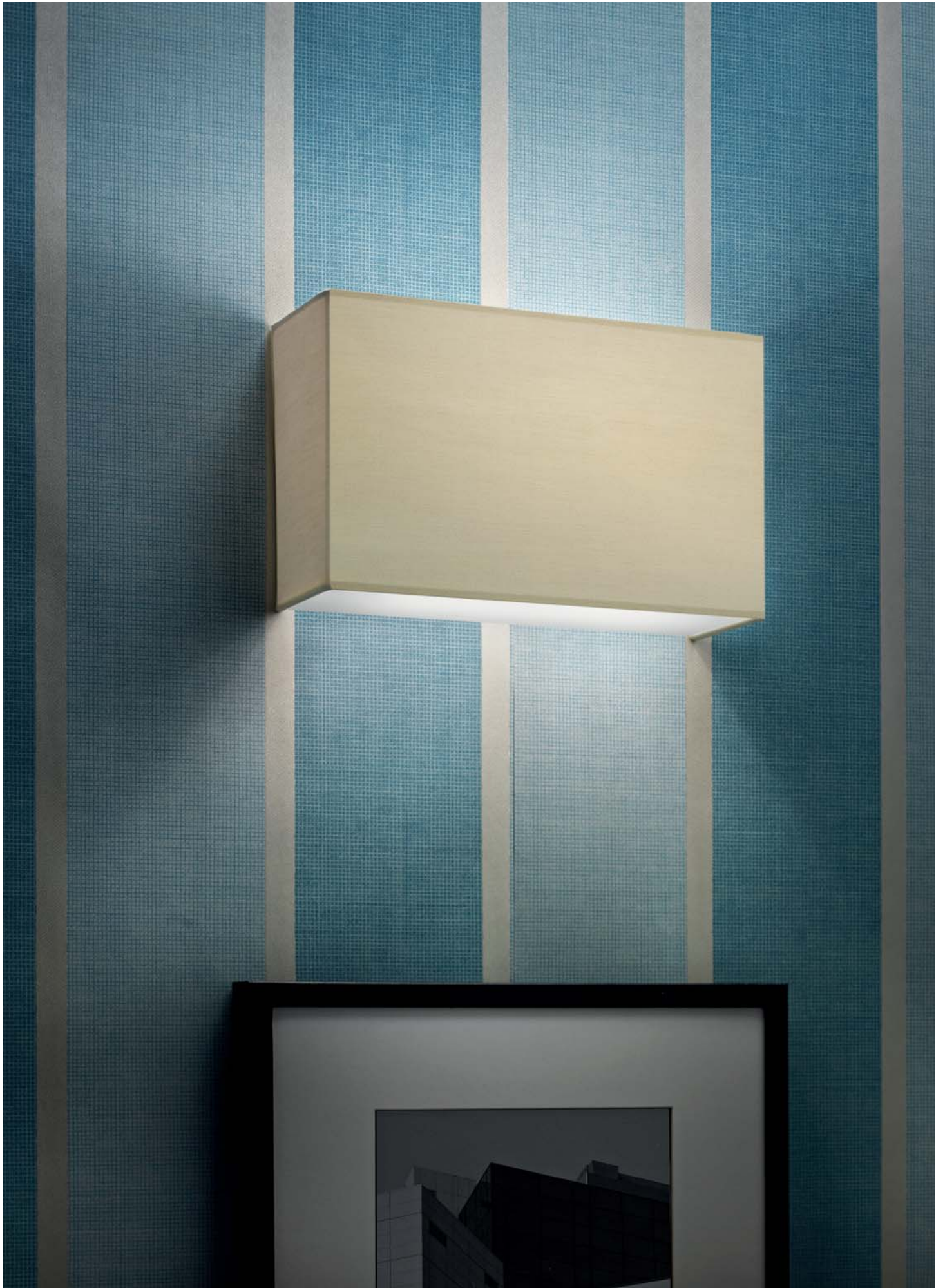

Square A2

SQUARE

Design by: Studio Stile Masiero

Strutture metalliche dalle molteplici forme sono elegantemente ricoperte da preziosi tessuti.

Different shaped, metallic structures are elegantly covered in precious fabrics.

Metallstrukturen in unterschiedlichsten Formen werden elegant von kostbaren Geweben überzogen.

Structures métalliques aux formes différentes recouvertes d'une façon élégante de précieux tissus.

Estructuras metálicas de múltiples formas son recubiertas elegantemente de preciados tejidos.

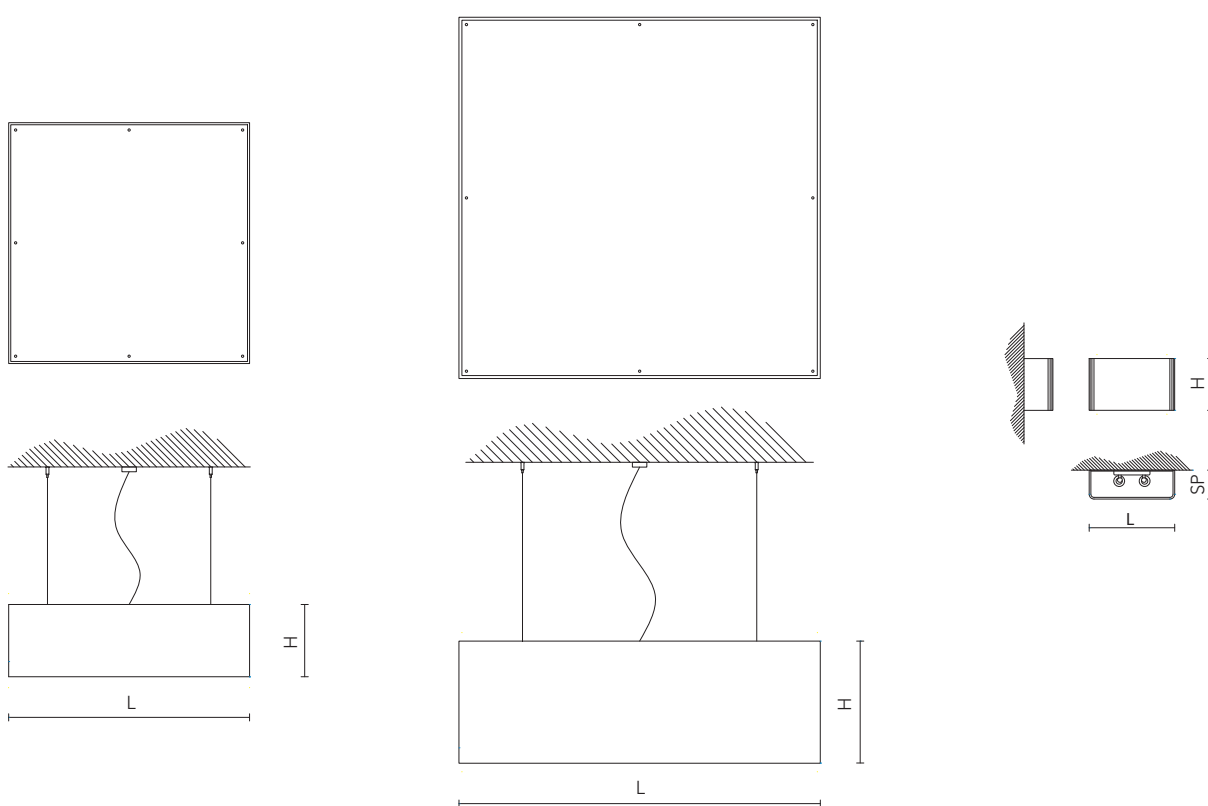

SQUARE S4 100

H 30 cm
11.90"

Ø 100x100 cm
39.40x39.40"

W 4x60w

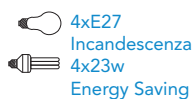

SQUARE S6 150

H 60 cm
23.70"

Ø 150x150 cm
59.10x59.10"

W 6x60w

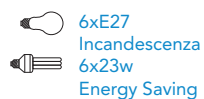

SQUARE A2

H 22 cm
8.70"

Ø 36 cm
14.20"

SP 12 cm
4.80"

W 2x40w

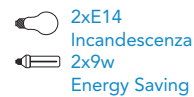

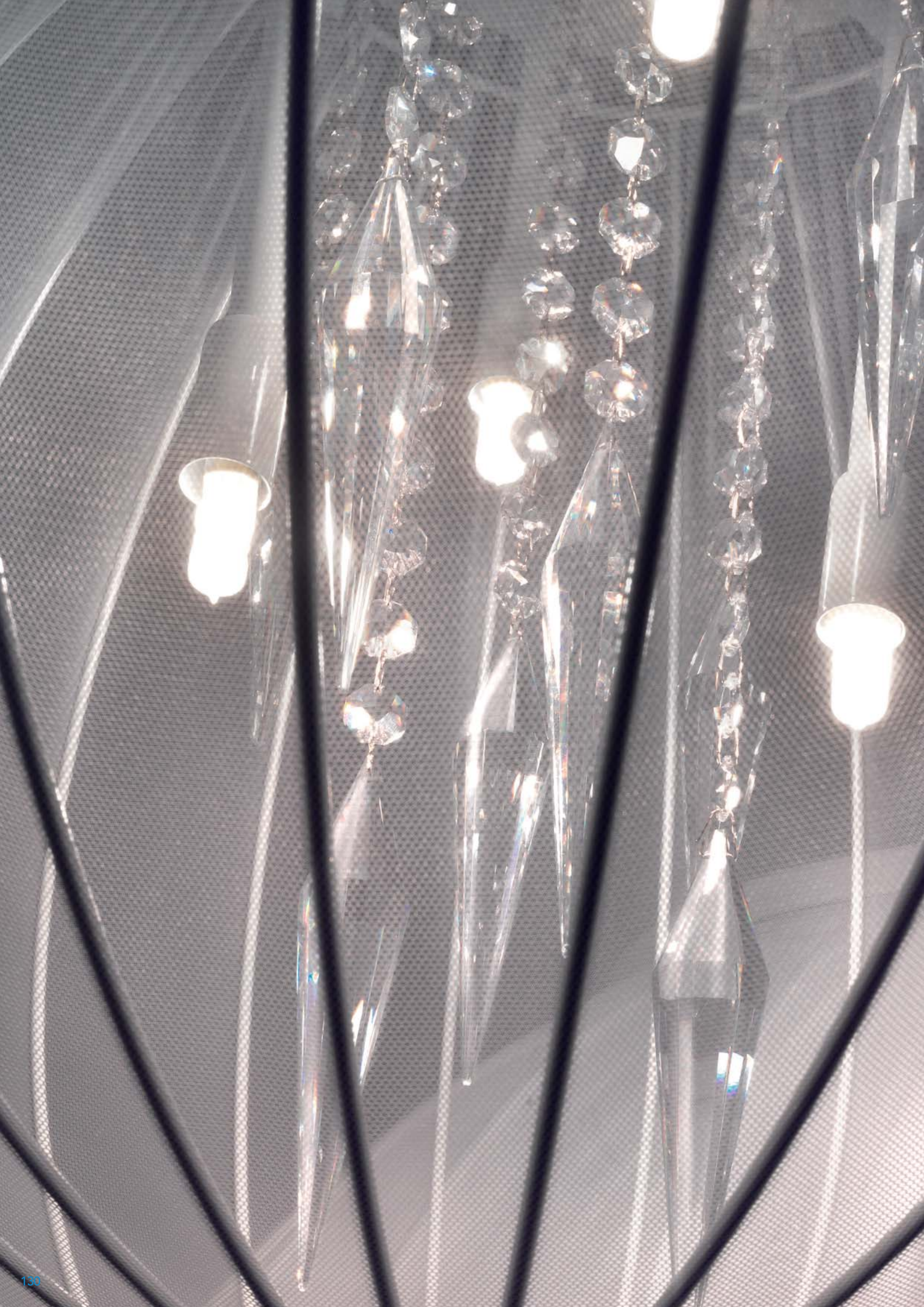



Sphere S4 50

Sphere S6 80

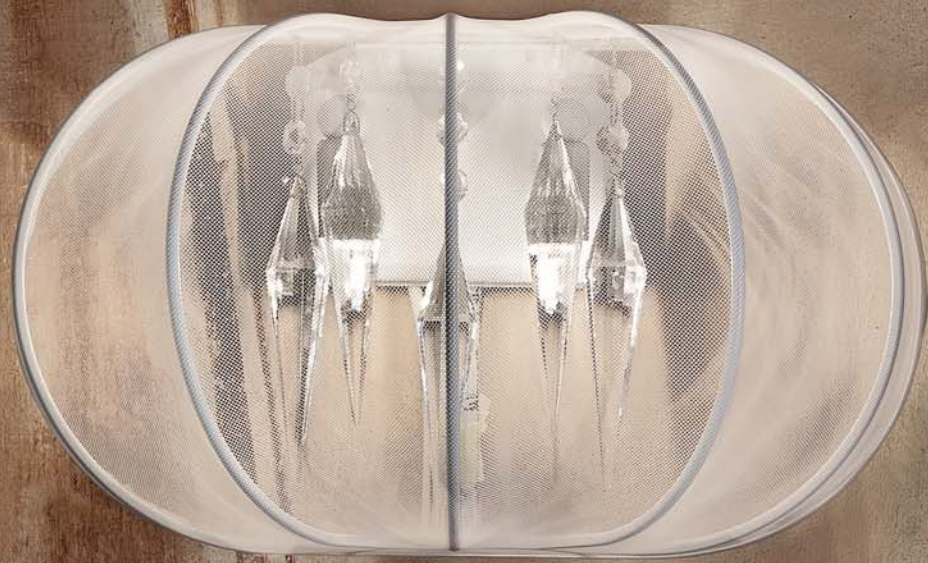

Sphere A2

SPHERE

Design by: Studio Stile Masiero

Strutture metalliche dalle molteplici forme sono elegantemente ricoperte da preziosi tessuti.

Different shaped, metallic structures are elegantly covered in precious fabrics.

Metallstrukturen in unterschiedlichsten Formen werden elegant von kostbaren Geweben überzogen.

Structures métalliques aux formes différentes recouvertes d'une façon élégante de précieux tissus.

Estructuras metálicas de múltiples formas son recubiertas elegantemente de preciados tejidos.

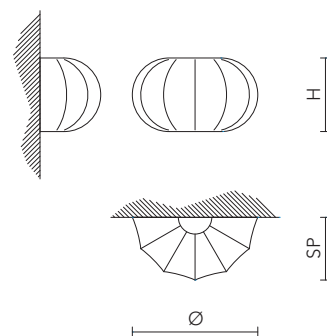
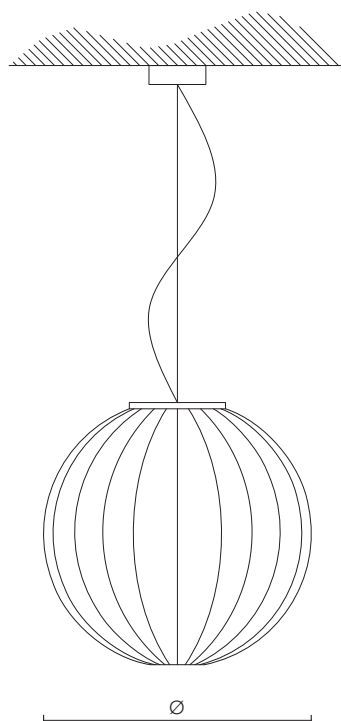
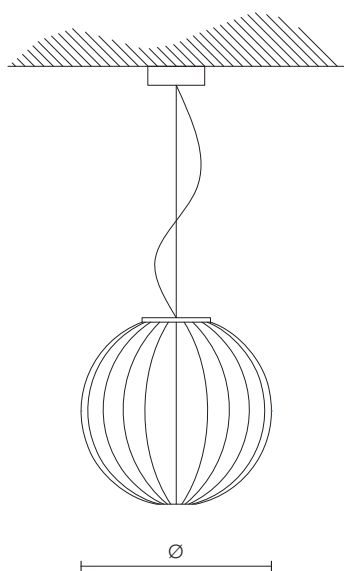

SPHERE S4 50

Ø 50 cm
19.70"

W 4x40w

4xG9
Alogena



SPHERE S6 50

Ø 80 cm
31.50"

W 6x40w

6xG9
Alogena



SPHERE A2

H 22 cm
8.30"

Ø 38 cm
15.00"

SP 20 cm
7.90"

W 2x25w

2xG9
Alogena





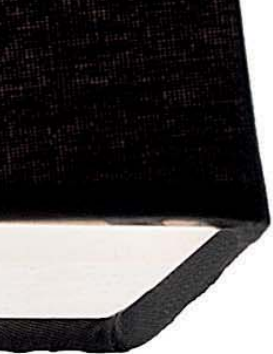

SLIM

Design by: Manuel Vivian

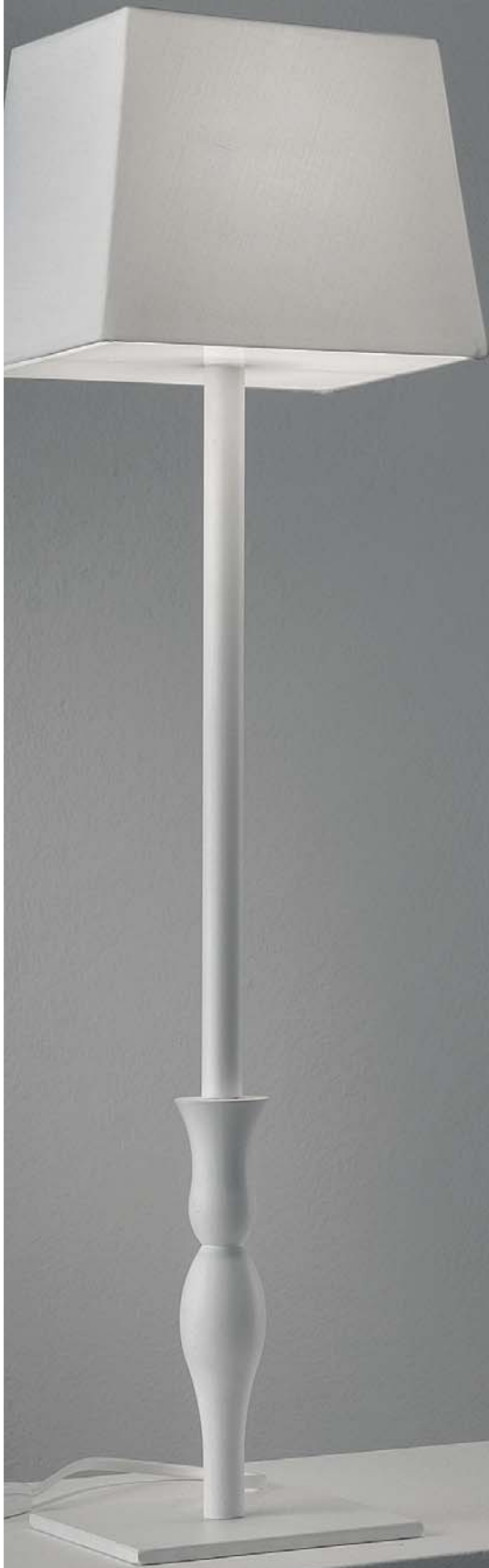

Slim TL1G



Slim A1





Slim TL1P



Slim TL1G



Slim A1

SLIM

Design by: Manuel Vivian

Lampada con struttura in metallo verniciato o decorato a foglia e paralume in prezioso tessuto accoppiato.

Lamp with metal structure either enamelled or foil decorated and lampshade in precious, double-face fabric.

Lampe mit lackierter oder mit Folie dekoriertes Metallstruktur und Lampenschirm aus kostbarem kaschiertem Gewebe.

Lampe avec structure en métal verni ou décoré à feuille d'or et abat-jour en précieux tissu double-face.

Lámpara con estructura de metal pintado y decorado de hoja y pantalla de precioso tejido acoplado.



GD-L
Foglia oro



WH-M
Bianco opaco

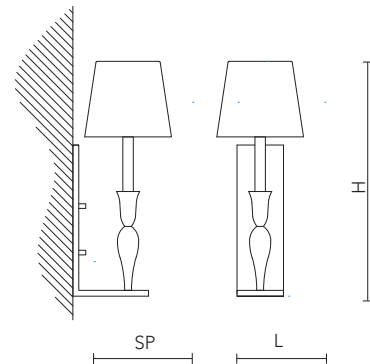
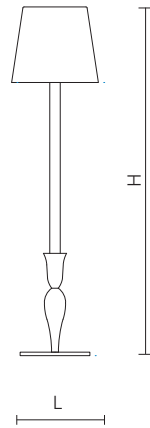
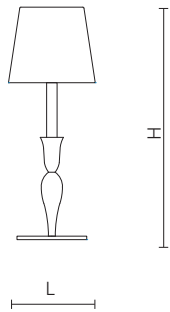

SLIM TL1P

H 40 cm
15.80"

L 16x16 cm
6.30x6.30"

W 1x60w

1xE14
Incandescenza



SLIM TL1G

H 60 cm
23.70"

L 16x16 cm
6.30x6.30"

W 1x46w

1xE14
Incandescenza



SLIM A1

H 42 cm
16.55"

L 16 cm
6.30"

SP 18 cm
7.10"

W 1x60w

1xE14
Incandescenza



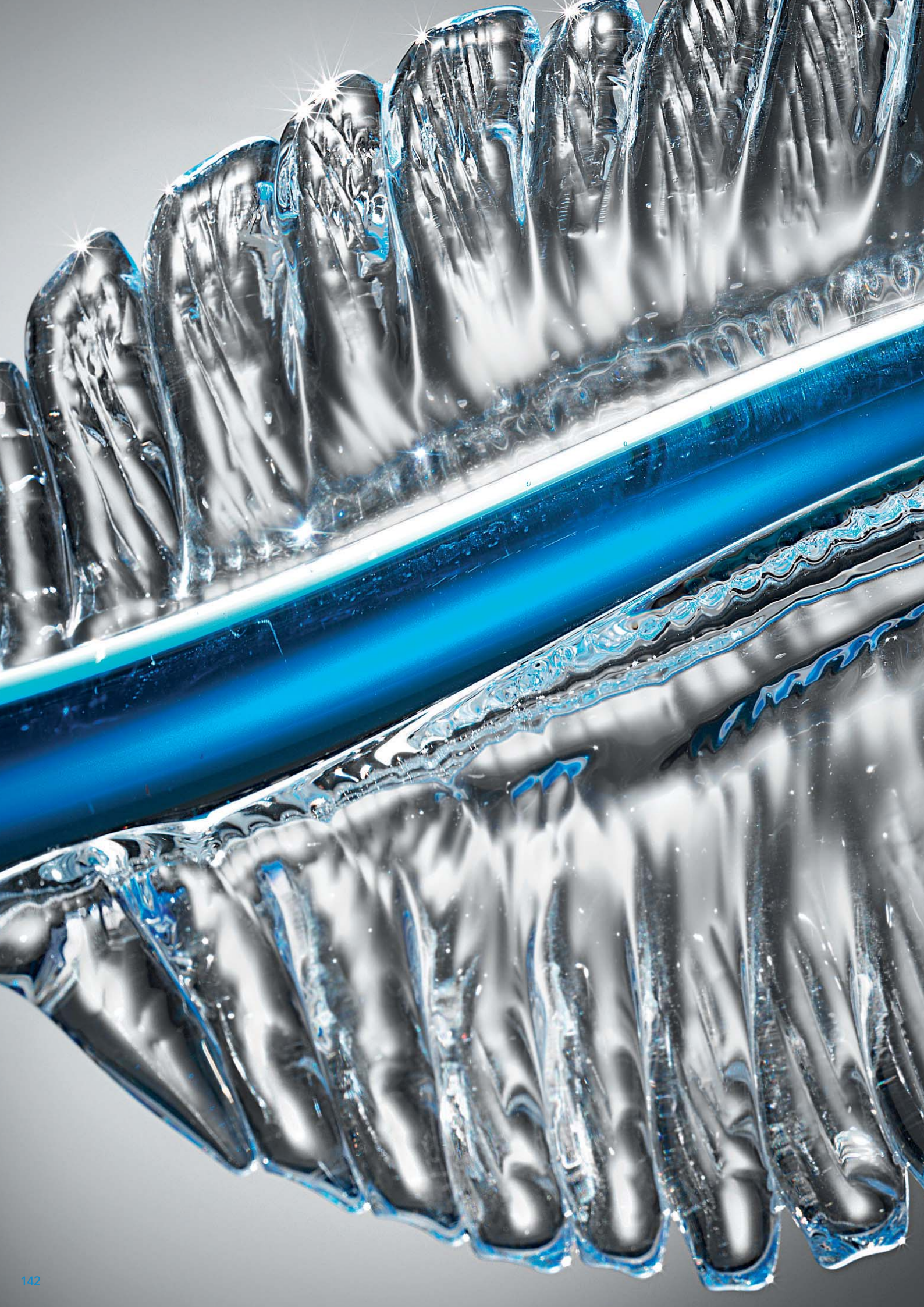



FLORA

Design by: Manuel Vivian



Flora SPOT

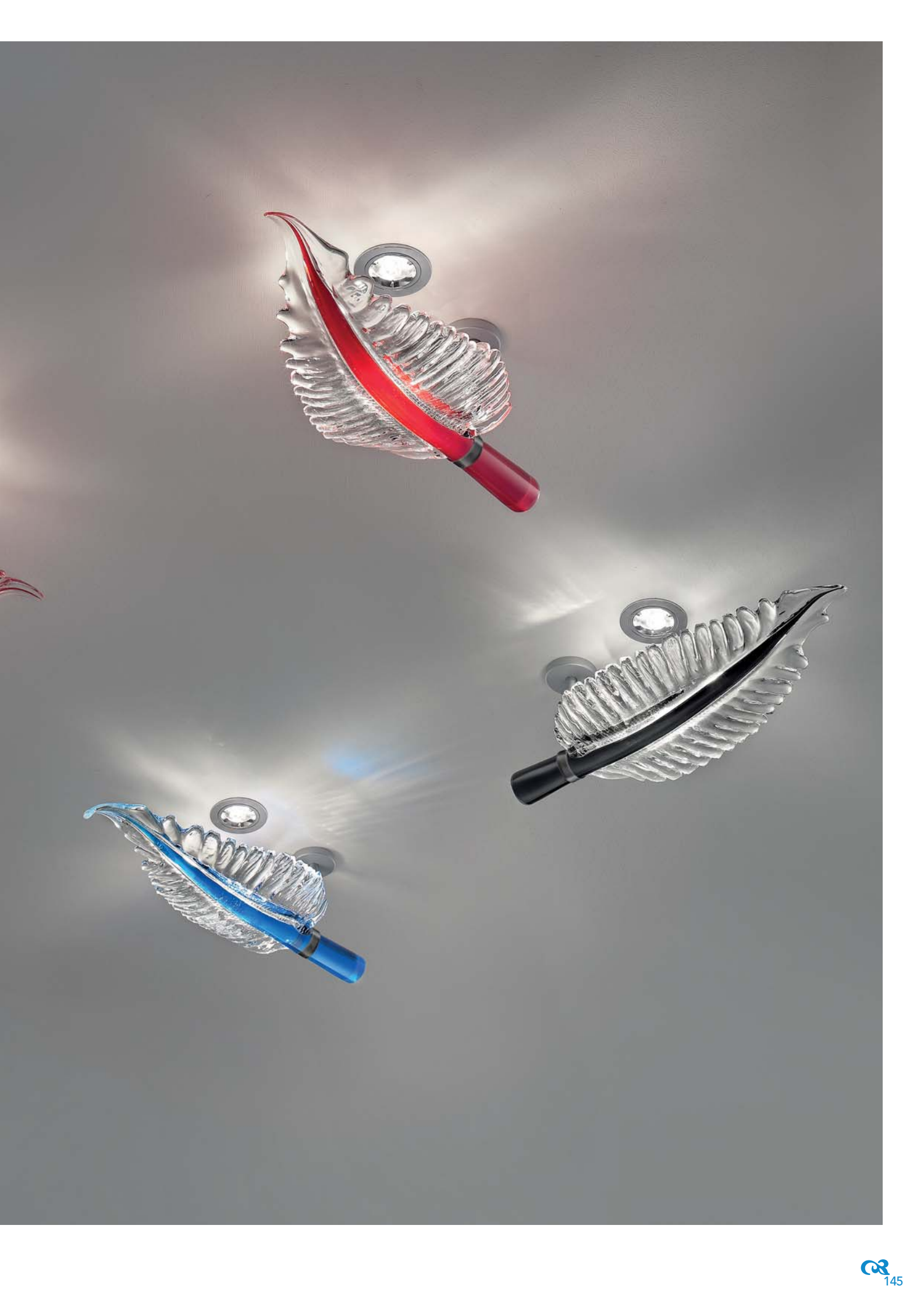



Flora A1



Flora A1

FLORA

Design by: Manuel Vivian

Lampada con struttura in metallo verniciato e diffusore a foglia di vetro di murano lavorato a mano.

Lamp with enamelled metal frame and hand-worked Murano glass leaf-shape shade.

Lampe mit Struktur aus lackiertem Metall und Diffusor aus handgearbeiteter Glasfolie aus Murano.

Lampe avec structure en métal verni et diffuseur à feuille en verre de Murano fait à la main.

Lámpara con estructura de metal pintado y difusor de hoja de vidrio de Murano elaborado a mano.



VBL
Stelo blu

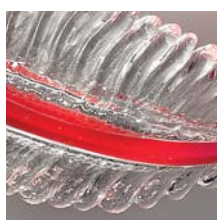

VRD
Stelo rosso



VBK
Stelo nero



VTR
Stelo trasparente

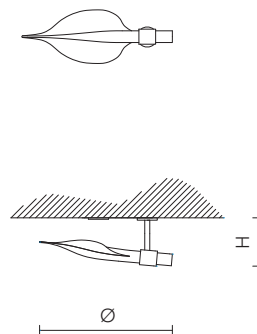
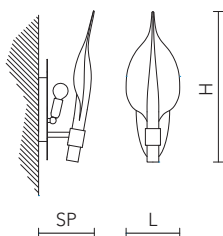



FLORA A1

H 50 cm
7.90"

Ø 20 cm
19.70"

SP 20 cm
7.90"

W 40w

 1xE14
Incandescenza
 1x9w
Energy saving



FLORA SPOT

H 16 cm
6.30"

Ø 45 cm
17.80"

W 1x35w

 1xGU10
Dicroica





A modern, minimalist white bookshelf is the central focus. On the left, a glass chandelier with three lit bulbs is partially visible. In the center, a dark blue vase sits on a shelf. To the right, several books are arranged on the shelves. The background is a plain, light-colored wall.

BIANCOMURANO

Design by: Paolo Crepax





Bianco Murano S30



Bianco Murano A5

BIANCOMURANO

Design by: Paolo Crepax

Lampada con montatura in vetro soffiato e lavorato a mano dai Maestri vetrai di Murano.

Lamp with frame in glass blown and hand-worked by the master glass-makers of Murano.

Lampe mit Fassung aus von den Glasbläsermeistern aus Murano von Hand bearbeitetem, geblasenem Glas.

Lampe avec structure en verre soufflé et travaillé à la main par les Maîtres-verriers de Murano.

Lámpara con montura de vidrio soplado y elaborado a mano por los Maestros vidrieros de Murano.

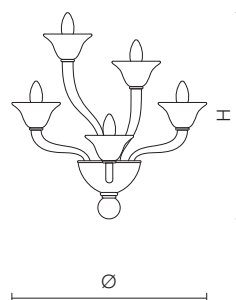
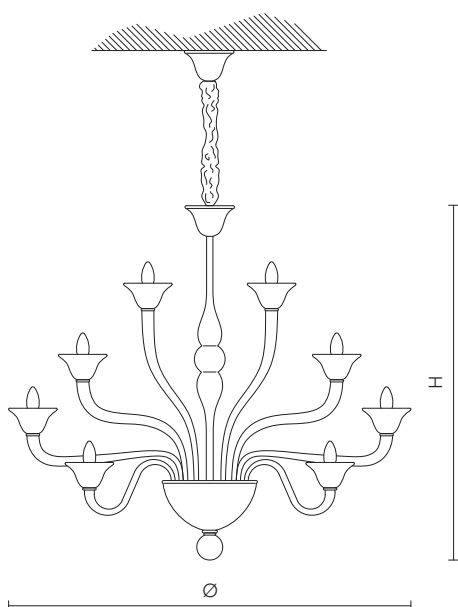



BIANCOMURANO S30

H 130 cm
51.20"

Ø 140 cm
55.20"

W 30x60w

 30xE14
Incandescenza
 30x9w
Energy Saving





BIANCOMURANO A5

H 50 cm
19.70"

L 60 cm
23.70"

SP 30 cm
11.90"

W 5x60w

 5xE14
Incandescenza
 5x9w
Energy Saving





MIR

Design by: Fly Design Studio



Mir S2



Mir S3



Mir STL3



Mir TL2



Mir PL6





MIR

Design by: Fly Design Studio

Lampada con montatura in metallo cromato, diffusore di luce in vetro triplex bianco latte, sfere in cristallo trasparente.

Chrome plated metal frame, opal glass triplex blown glass sphere, transparent crystal balls.

Leuchte mit verchromter Metallfassung, Lichtdiffusor aus Triplex Glas, milchfarbig, Kugeln aus transparentem Kristall.

Lampe avec monture en métal chromé, diffuseur de lumière en verre triplex blanc lait, sphères en cristal transparent.

Lámpara con cuerpo de metal cromado, difusor de luz de vidrio triplex blanco leche, esfera de cristal transparente.



Bianco Lucido

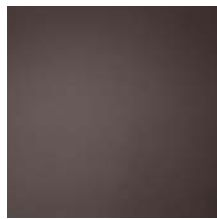

Bronzo opaco

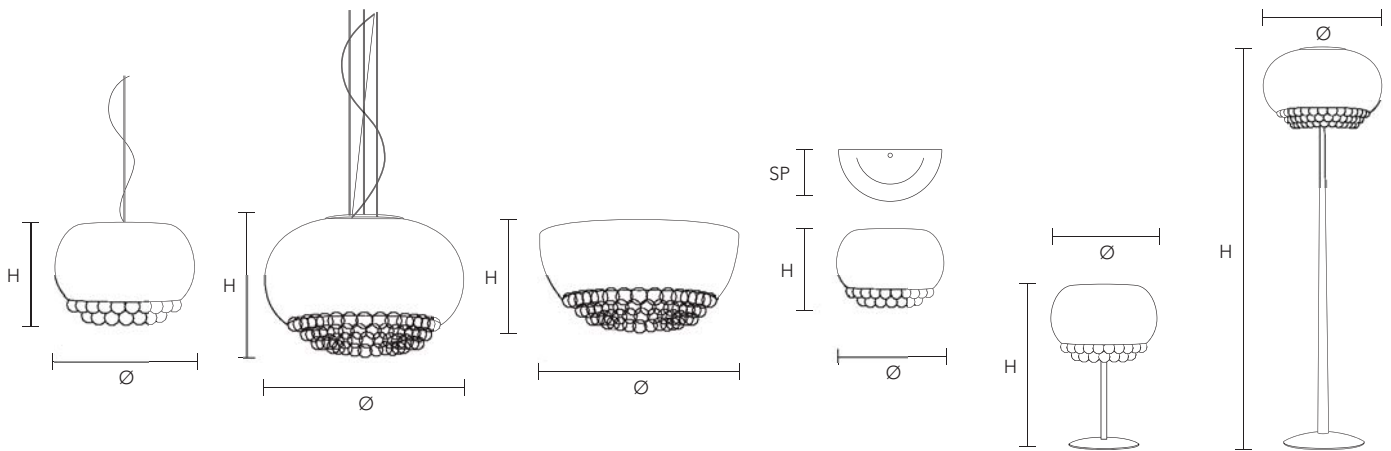

MIR S2

H 25 cm
9.95"

Ø 30 cm
11.80"

W 2x60w

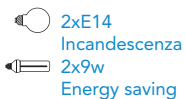

MIR S3

H 30 cm
11.80"

Ø 45 cm
17.70"

W 3x60w

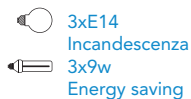

MIR PL6

H 25 cm
9.95"

Ø 45 cm
17.70"

W 6x60w

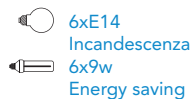

MIR A1

H 22 cm
8.66"

L 30 cm
11.80"

SP 15 cm
5.90"

W 1x100w

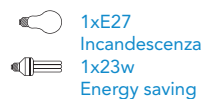

MIR TL2

H 45 cm
17.70"

Ø 30 cm
11.80"

W 2x60w

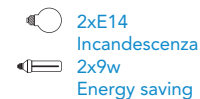

MIR STL3

H 185 cm
72.85"

Ø 45 cm
17.70"

W 3x60w

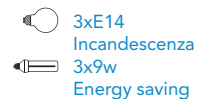





GIRO

Design by: Crepax - Zanon





Girò PL4

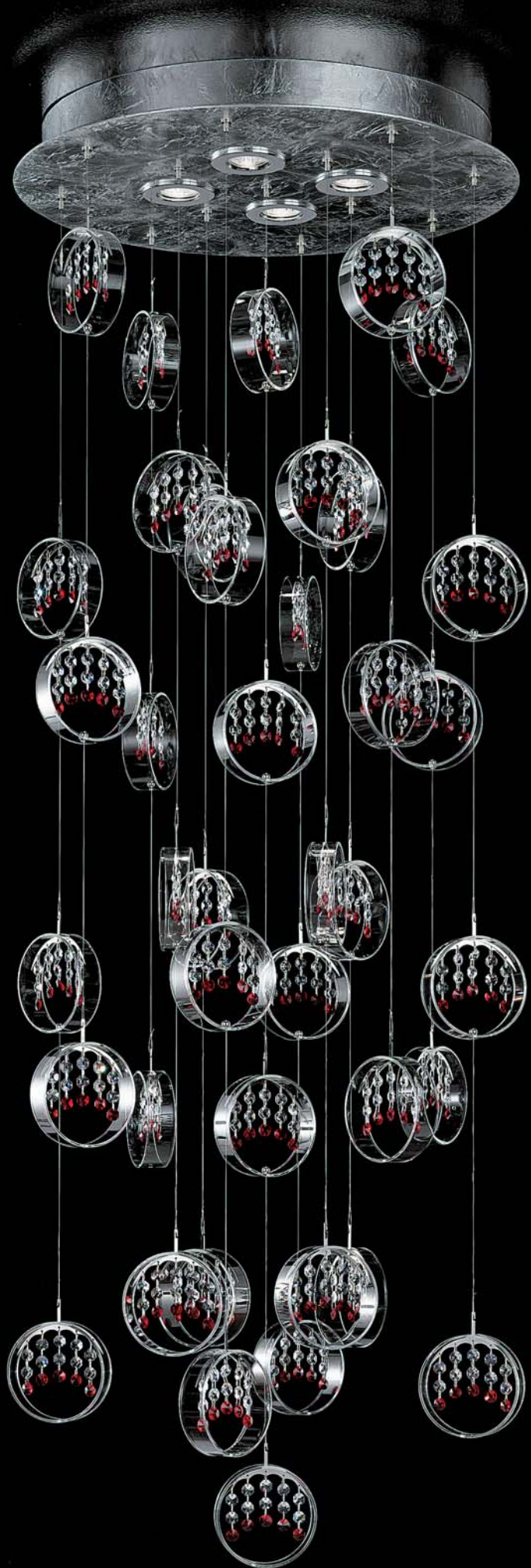

Girò PL4





Girò S3





Girò S3





GIRÒ

Design by: Crepax - Zanon

Lampada con montatura in acciaio AISI 304, anello in vetro triplex di Murano soffiato, pendagli in cristallo trasparente.

Stainless steel AISI 304 frame, triplex Murano glass blown ring, transparent crystal pendants.

Leuchte mit Fassung aus Stahl AISI 304, Ring aus Triplex MuranoGlas, mundgeblasen, Pendel aus transparentem Kristall.

Lampe avec monture en acier AISI 304, bague en verre soufflé triplex de Murano, pendeloques en cristal transparent.

Lámpara con cuerpo de acero AISI 304, anillo de vidrio soplado triplex de Murano, colgantes de cristal transparente.

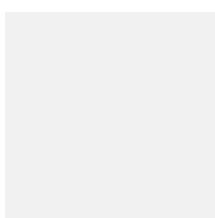

Bianco

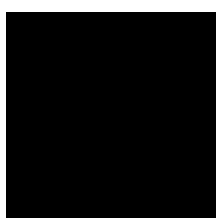

Nero



Rosso

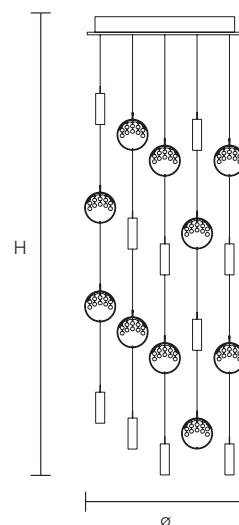
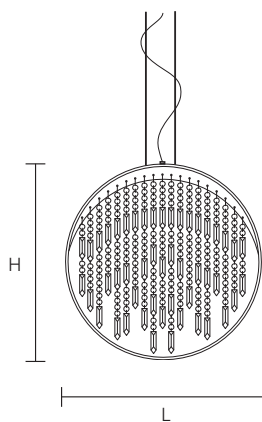
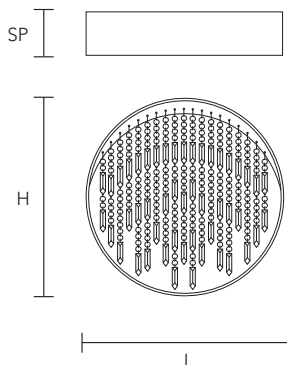

GIRÒ A3

H 48 cm
18.90"

L 48 cm
18.90"

SP 10 cm
3.95"

W 3x60w

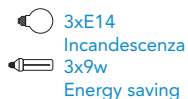

GIRÒ S3

H 48 cm
18.90"

L 48x10 cm
18.90x3.95"

W 3x60w

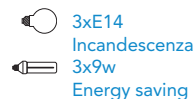

GIRÒ PL4

H 180 cm
70.90"

Ø 60 cm
23.65"

W 4x50w





MISSIÀ

Design by: Manuel Vivian



Missià TL3



Missià STL3



Missià A1





Missià S1





Missià TL3

MISSIÀ

Design by: Manuel Vivian

Lampada con struttura in metallo verniciato, diffusore di luce in vetro triplex soffiato di Murano.

Powder coated metal frame, handmade blown triplex Murano glass.

Lampe mit lackierter Metallstruktur, Lichtdiffusor aus geblasenem Triplexglas aus Murano.

Lampe avec structure en métal verni, diffuseur de lumière en verre triplex soufflé de Murano.

Lámpara con estructura de metal barnizado, difusor de luz de vidrio triplex soplado de Murano.



Bianco

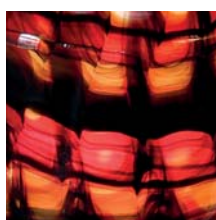

Multicolor

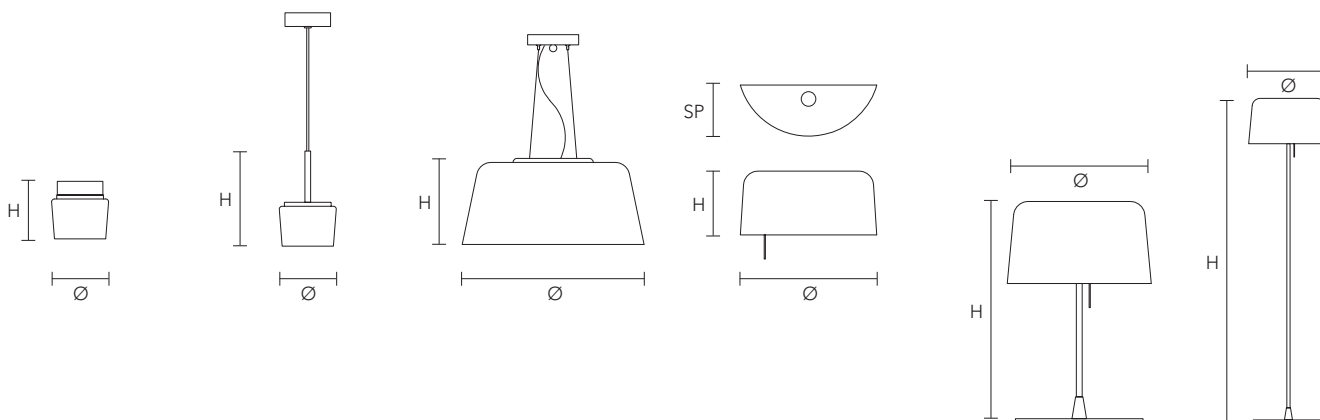

MISSIÀ PL1

H 13 cm
5.10"

Ø 11 cm
4.40"

W 1 x40w



MISSIÀ S1

H 18 cm
7.10"

Ø 11 cm
17.70"

W 1x40w



MISSIÀ S3

H 25 cm
9.90"

Ø 50 cm
19.70"

W 3x100w

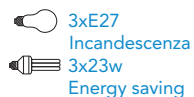

MISSIÀ A1

H 18 cm
7.10"

L 38 cm
15.00"

SP 13 cm
5.20"

W 1x100w

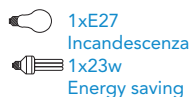

MISSIÀ TL3

H 70 cm
27.60"

Ø 40 cm
15.80"

W 3x100w

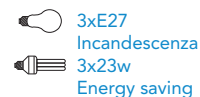

MISSIÀ STL3

H 170 cm
67.00"

Ø 40 cm
15.80"

W 3x100w

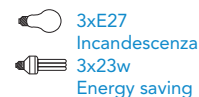





PIZZO

Design by: Fly Design Studio



Pizzo TL3G





Pizzo PL4



Pizzo TL2P



Pizzo STL3

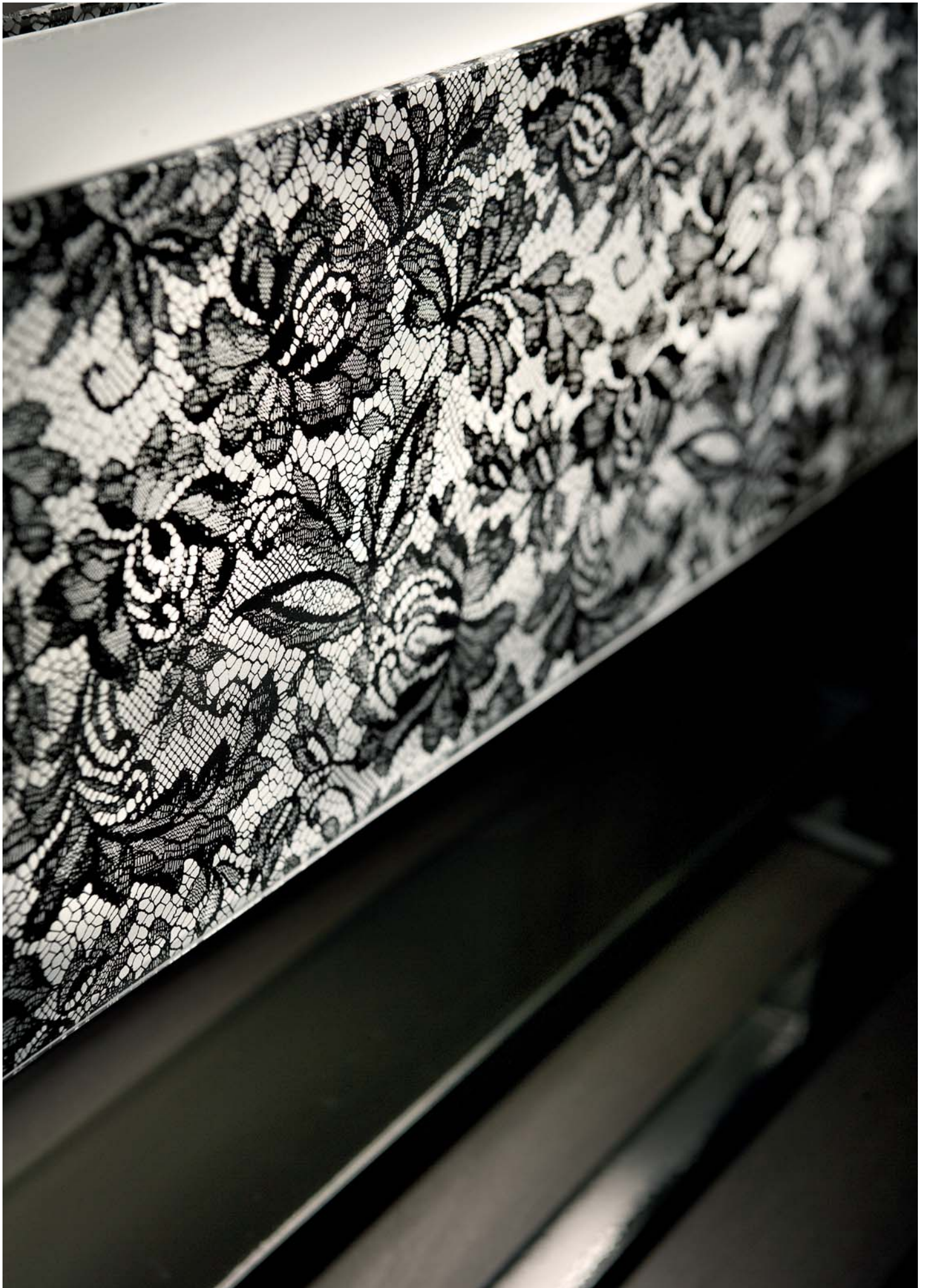

PIZZO

Design by: Fly Design Studio

Lampada con struttura in metallo verniciato, diffusore in lastra di vetro serigrafato.

Powder coated metal frame, screen-printed decorative glass.

Lampe mit lackierter Metallstruktur, Diffusor aus Glasplatte mit Siebdruck.

Lampe avec structure en métal verni, diffuseur en plaque de verre sérigraphié.

Lámpara con estructura de metal barnizado, difusor de hoja de vidrio serigrafiado.



Pizzo bianco



Pizzo nero

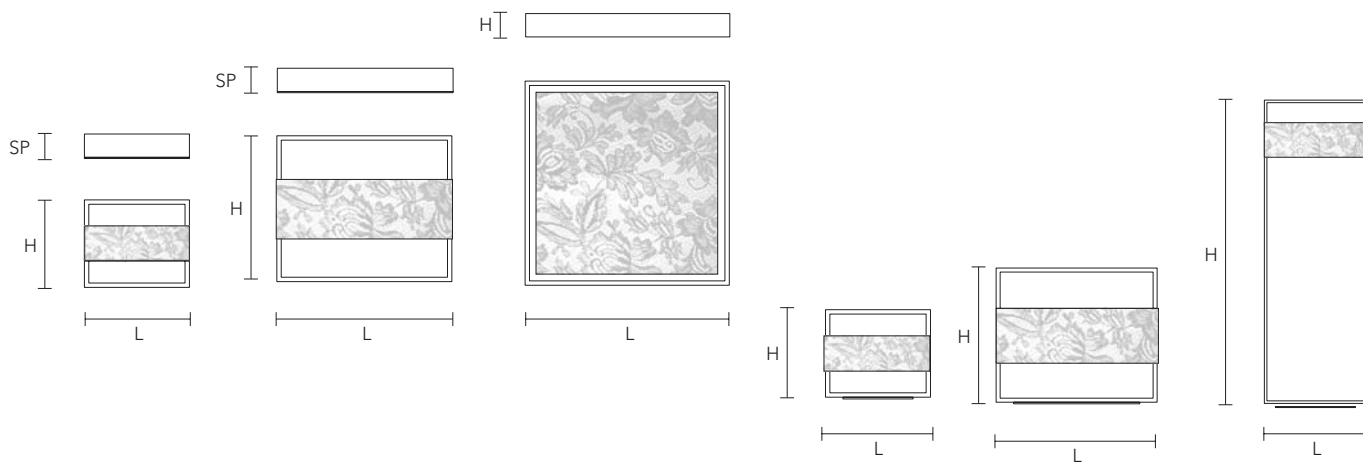

PIZZO A2P

H 30 cm
11.90"

L 36 cm
14.20"

SP 8 cm
3.20"

W 2x60w

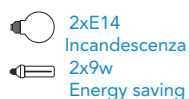

PIZZO A3G

H 50 cm
15.75"

L 60 cm
23.70"

SP 8 cm
3.20"

W 3x100w

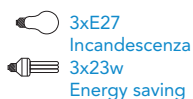

PIZZO PL4

H 10 cm
3.95"

L 70x70 cm
27.50x27.50"

W 4x100w

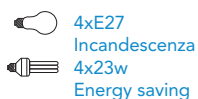

PIZZO TL2P

H 31 cm
12.30"

L 36x8 cm
14.20x3.15"

W 2x60w

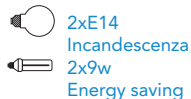

PIZZO TL3G

H 51 cm
20.10"

L 60x8 cm
23.60x3.15"

W 3x100w

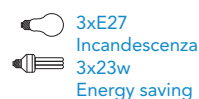

PIZZO STL3

H 180 cm
70.87"

L 60x8 cm
17.72"

W 3x100w

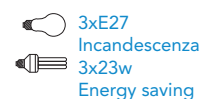



BLOB

Design by: Fly Design Studio



Blob A2 45





Blob A2 45



Blob A2 26





Blob A2 45

BLOB

Design by: Fly Design Studio

Lampada con struttura
in metallo verniciato.

Powder coated metal
frame.

Lampe mit lackierter
Metallstruktur.

Lampe avec structure
en métal verni.

Lámpara con
estructura de metal
barnizado.



Foglia argento

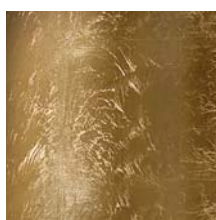

Foglia oro



Bianco lucido



Magenta lucido



Nero lucido

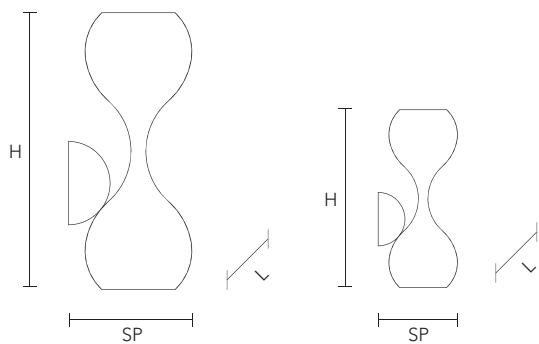

BLOB A2 45

H 45 cm
17,80"

L 18 cm
7,10"

SP 20 cm
7,90"

W 2x100w



2xE27 PAR30

BLOB A2 26

H 26 cm
10,30"

Ø 10 cm
4,00"

SP 12 cm
4,80"

W 2x50w



2xGU10
Dicroica



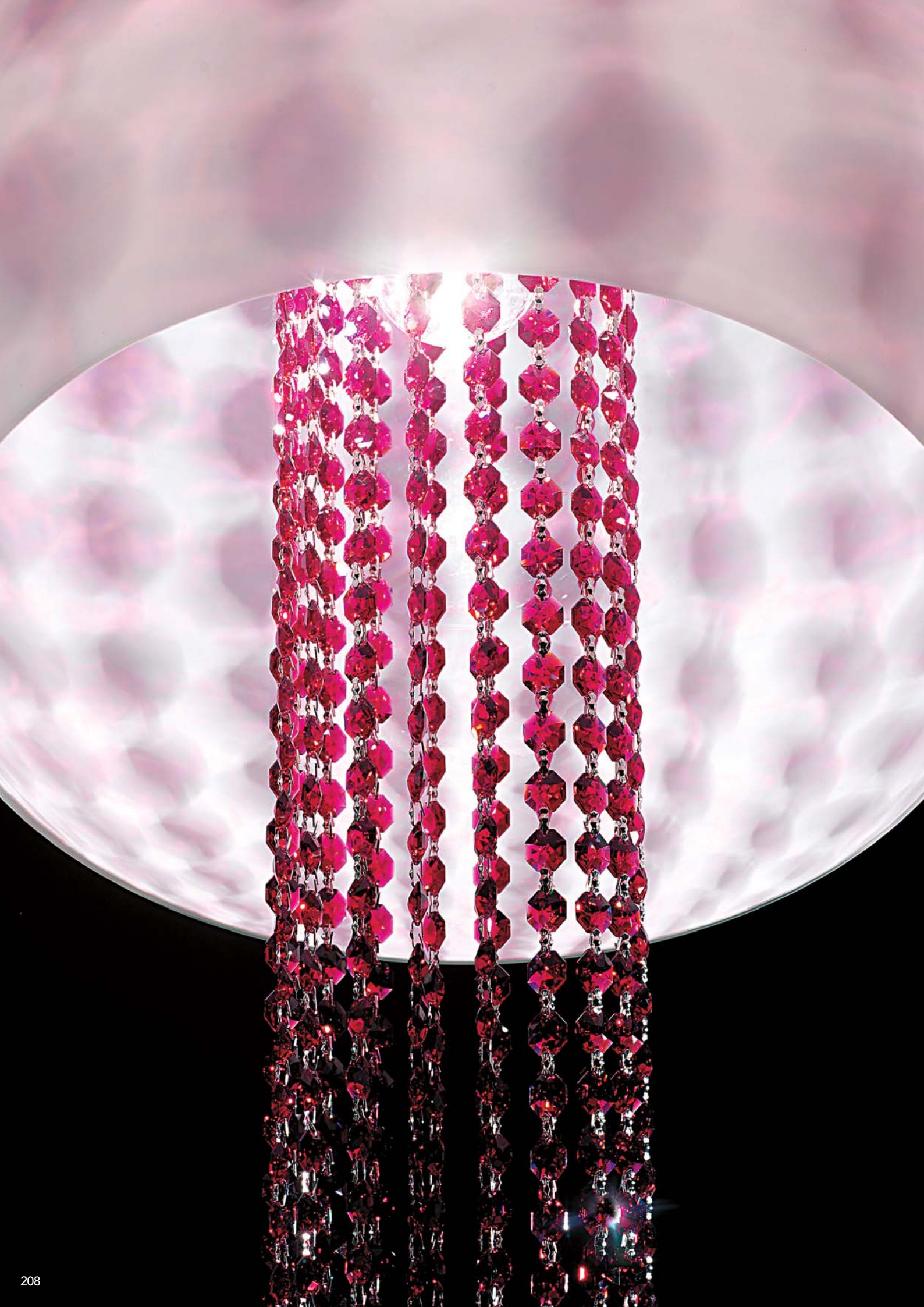

FRISÉ

Design by: Fly Design Studio



Frisé S1 Ø40



Frisé S1 Ø40



Frisé TL1 Ø30



Frisé TL1 Ø20

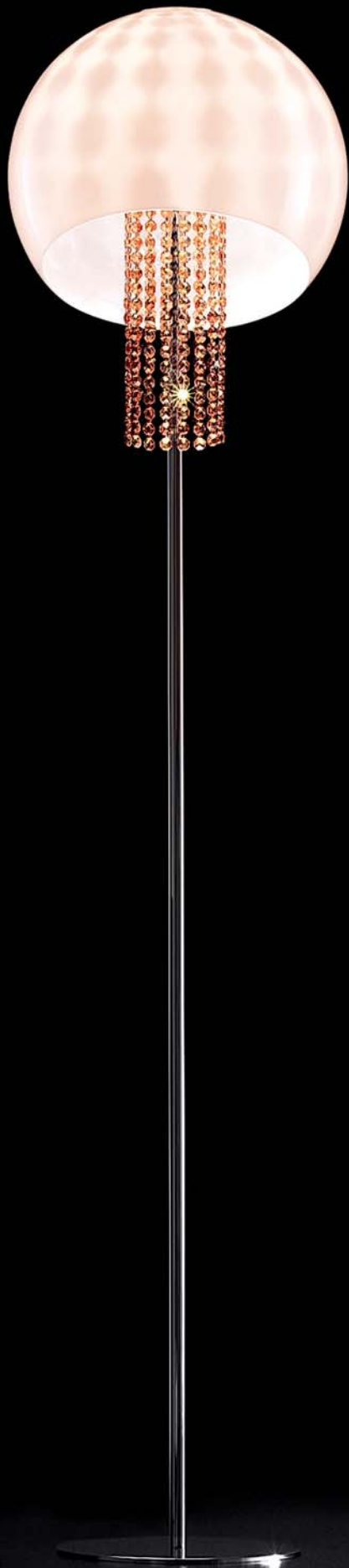

Frisé STL1

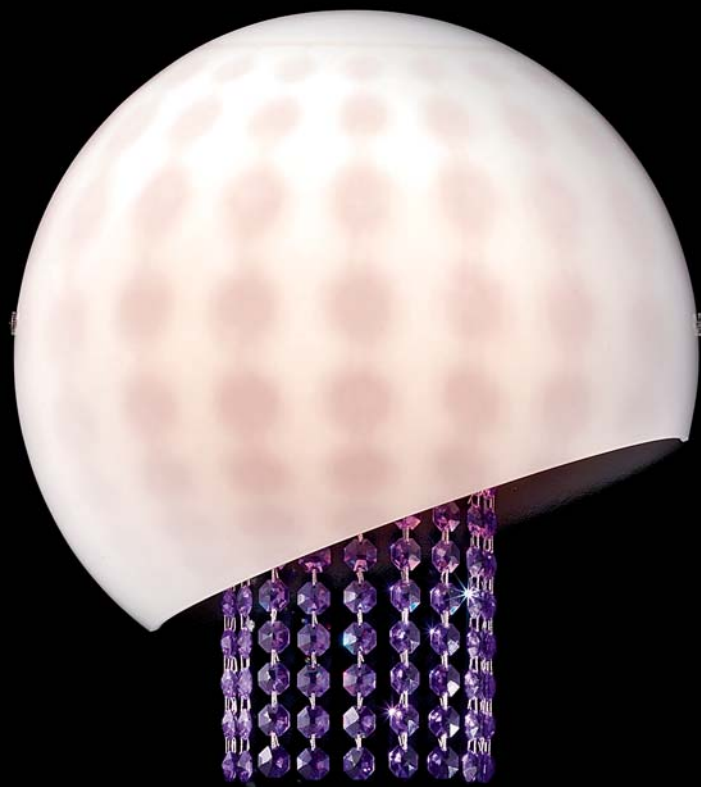

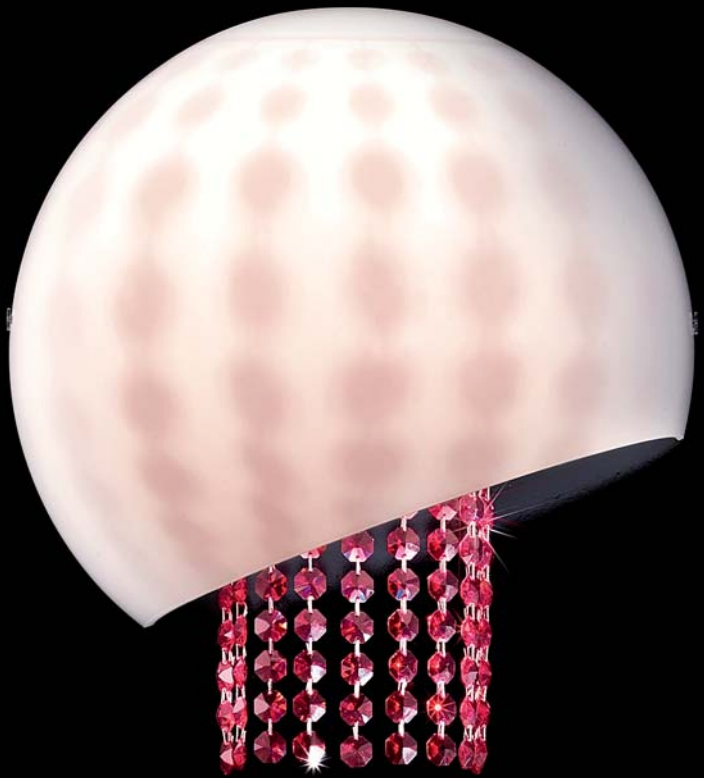



Frisé S1 Ø20



Trasparente



Saphire

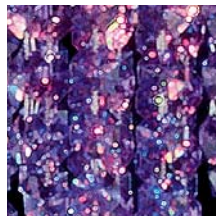

Viola

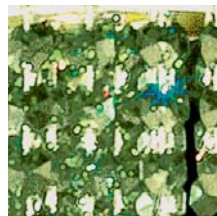

Light Peridot

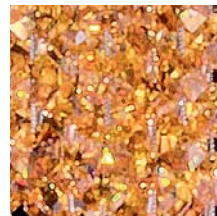

Ambra

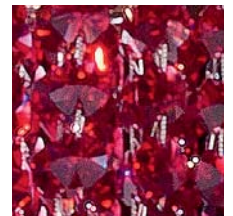

Rosso

FRISÉ

Design by: Fly Design Studio

Lampada con montatura in metallo cromato, diffusore di luce sferico bianco latte in vetro soffiato, pendagli in cristallo Strass Swarovski colorato.

Chrome plated metal frame, opal white blown glass sphere, coloured Strass Swarovski crystal pendants.

Lampe mit aufstellung in Chrom Metall diffusor des liches kugelförmigem hellem Milch-weißem in geblasenem Glas, anhänger in Kristallstrass buntes Swarovski.

Lampe avec monture en métal chromé, diffuseur de lumière sphérique blanc lait en verre soufflé, breloques en cristal Strass Swarovski teinté.

Lámpara con montura en metal cromado, difusor de luz esférico blanco leche en vidrio soplado colgantes en cristal Strass Swarovski coloreado.

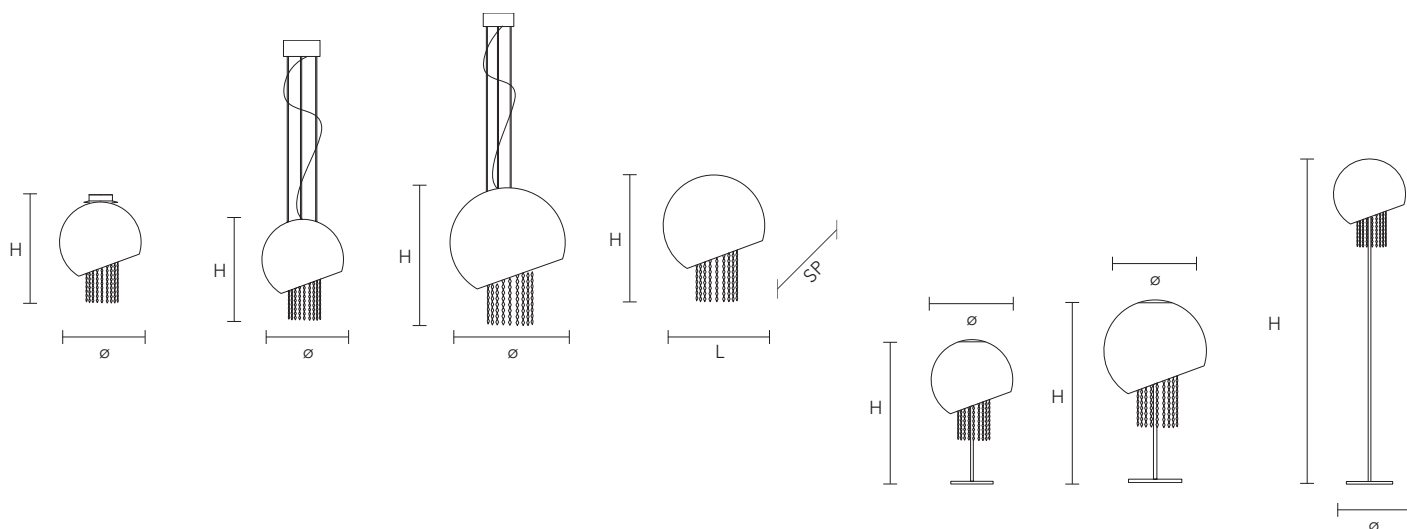

FRISÉ PL1 Ø20

H 30 cm
11.82"

Ø 20 cm
7.88"

W 1x60w

1xE14 Incandescenza
1x9w Energy saving



FRISÉ S1 Ø20

H 30 cm
11.82"

Ø 20 cm
7.88"

W 1x60w

1xE14 Incandescenza
1x9w Energy saving



FRISÉ S1 Ø40

H 50 cm
19.70"

Ø 42 cm
16.53"

W 1x150w

1xE27 Incandescenza
1x23w Energy saving



FRISÉ A1

H 40 cm
15.75"

L 30 cm
11.82"

SP 15 cm
5.91"

W 1x100w

1xE27 Incandescenza
1x23w Energy saving



FRISÉ TL1 Ø20

H 33 cm
13.00"

Ø 20 cm
7.88"

W 1x60w

1xE14 Incandescenza
1x9w Energy saving



FRISÉ TL1 Ø30

H 54 cm
21.26"

Ø 30 cm
11.82"

W 1x100w

1xE27 Incandescenza
1x23w Energy saving



FRISÉ STL1

H 184 cm
72.45"

Ø 40 cm
15.75"

W 1x100w

1xE27 Incandescenza
1x23w Energy saving







DONNA

Design by: Fly Design Studio



Donna S1



Donna TL1

Donna STL1



Donna SPOT

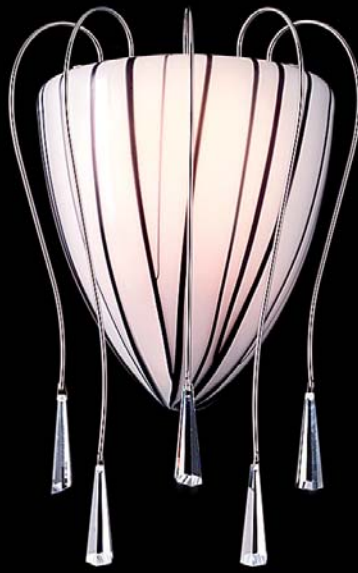

DONNA

Design by: Fly Design Studio

Lampada con montatura e zampilli in metallo cromato, pendagli in cristallo al 30% di piombo, diffusore di luce in vetro triplex soffiato con striature in pasta di vetro colorato.

Chrome plated metal frame, chrome plated gushes, lead crystal pendants 30% Pbo, opa white blown triplex glass with coloured glass stripes.

Lampe mit aufstellung und strahlen im ChromMetall anhängen im Kristall bis 30% von Blei diffusor des Lichtes in geblasenem Glastriplex mit Schrammen in der Paste des bunten Glases.

Lampe avec monture et dessins en métal chromé, breloques en cristal à 30% de plomb, diffuseur de lumière en verre triplex soufflé avec rayures en pâte de verre teinté.

Lámpara con montura y diseños en metal cromado, colgante en cristal al 30% de plomo, difusor de luz en vidrio tríplex soplado con rayaduras en pasta de vidrio coloreado.

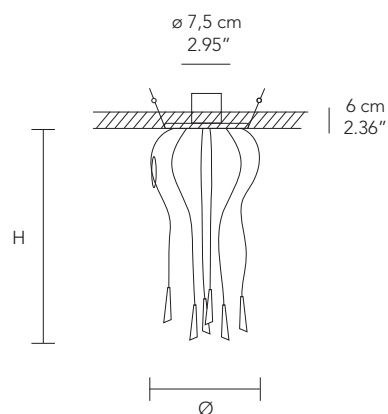

DONNA SPOT

H 20 cm
7.88"

Ø 11 cm
4.34"

W 1x35w

 1xGU 5.3
Dicroica
Low voltage





Bianco-Bianco



Bianco-Nero

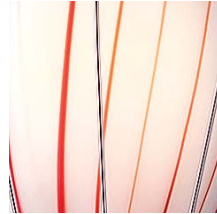

Bianco-Rosso

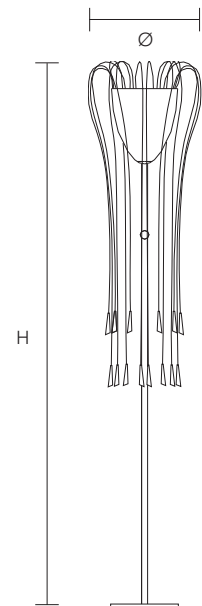
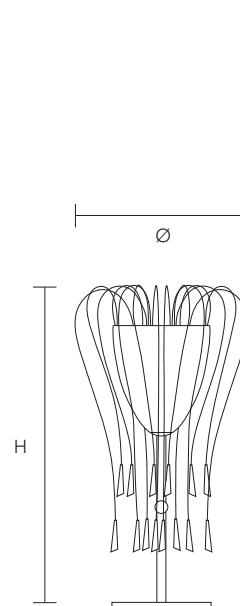
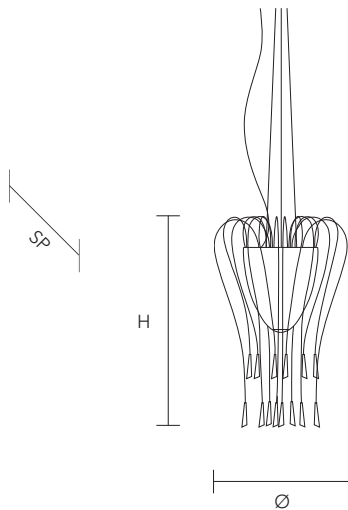
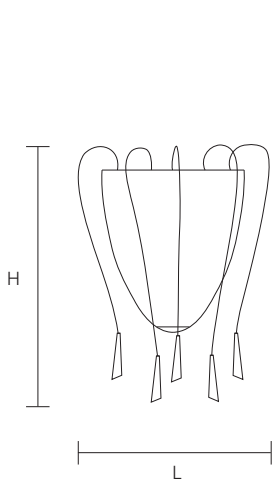



DONNA A1

H 40 cm
15.75"

L 30 cm
11.82"

SP 15 cm
5.91"

W 1x150w

 1xE27
Incandescenza
 1x23w
Energy saving





DONNA S1

H 62 cm
24.41"

Ø 39 cm
15.36"

W 1x150w

 1xE27
Incandescenza
 1x23w
Energy saving





DONNA TL1

H 72 cm
28.35"

Ø 39 cm
15.36"

W 1x150w

 1xE27
Incandescenza
 1x23w
Energy saving





DONNA STL1

H 200 cm
78.75"

Ø 45 cm
17.72"

W 1x150w

 1xE27
Incandescenza
 1x23w
Energy saving





PROFONDO ROSSO

Design by: Fly Design Studio



Profondo Rosso S8





Profondo Rosso A2

PROFONDO ROSSO

Design by: Fly Design Studio

Lampade con montatura in vetro soffiato e lavorate a mano dai Maestri vetrai di Murano.

Hand made glass frame blown by the Murano glass master blowers.

Lampe mit aufstellung im geblasenem Glas und vom meisterglaser von Murano handgearbeitet.

Lampe avec monture en verre soufflé et travaillé à la main par les maîtres vitriers de Murano.

Lámpara con montura en vidrio soplado y trabajado a mano por los maestros vidrieros de Murano.



Vetro trasparente

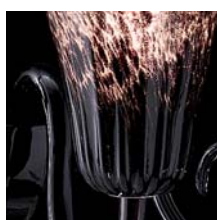

Vetro nero



Vetro rosso

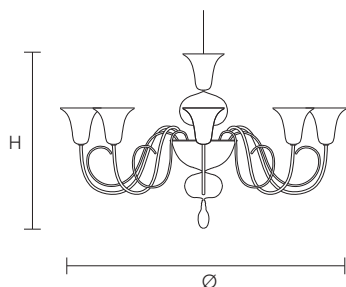
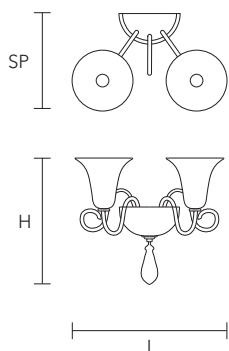

PROFONDO ROSSO A2

H 36 cm
14.20"

L 36 cm
14.20"

SP 30 cm
11.80"

W 2x60w

 2xE14
Incandescenza

PROFONDO ROSSO S8

H 75 cm
29.55"

Ø 110 cm
43.30"

W 8x60w

 8xE14
Incandescenza







NEROSOLE

Design by: Crepax-Zanon

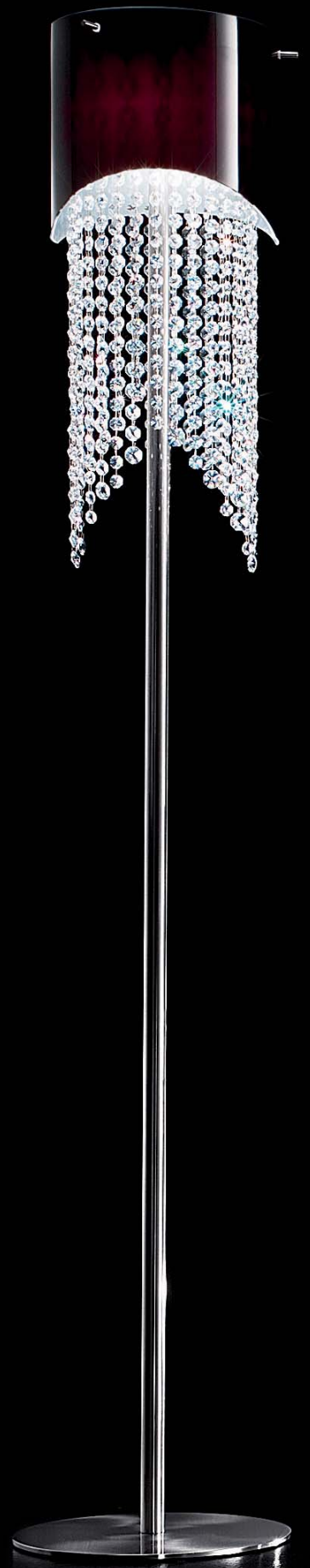

Nerosole STL3



Nerosole TL3



Nerosole PL3





Nerosole A2



Nerosole S5 Ø36

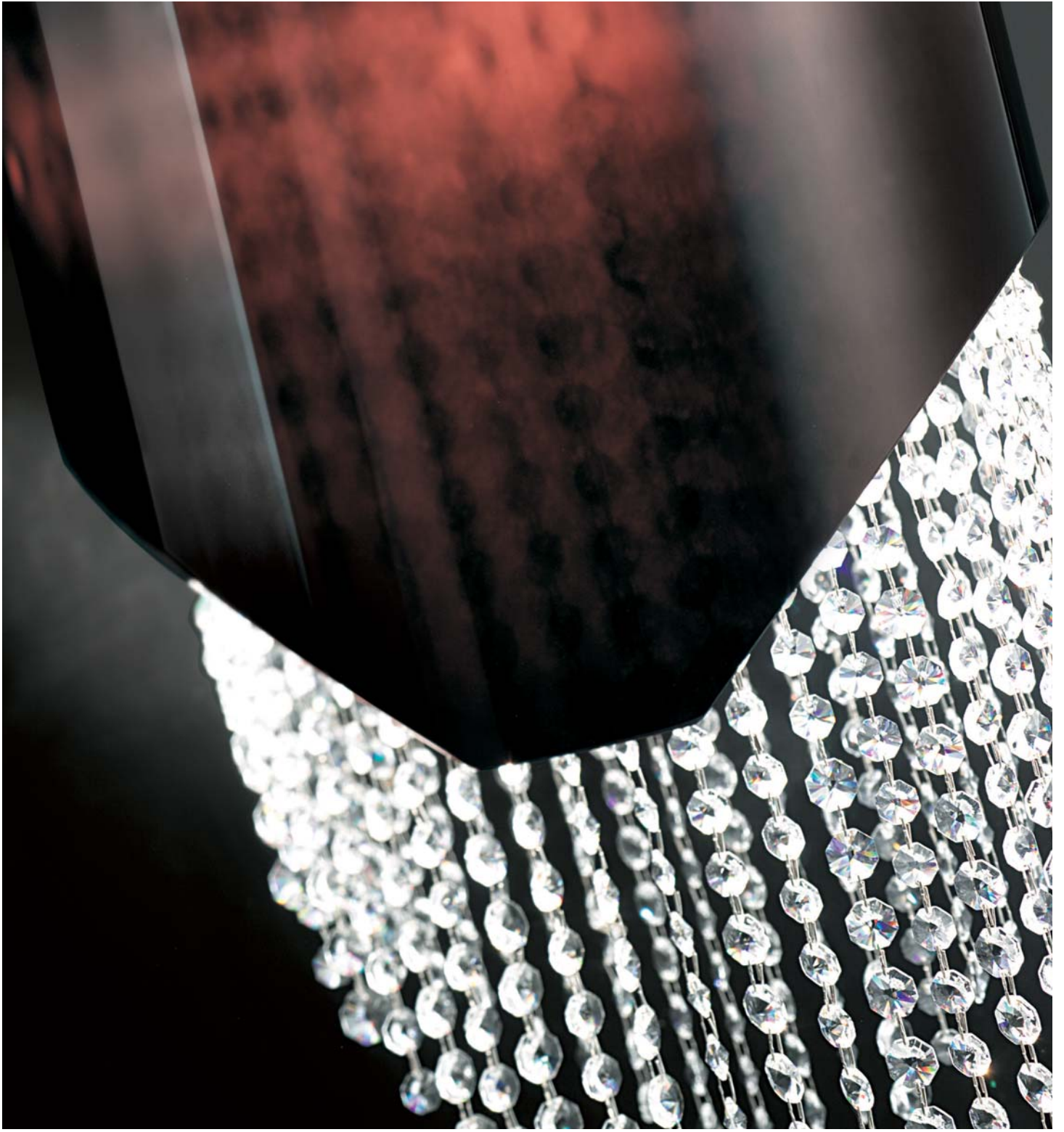

NEROSOLE

Design by: Crepax-Zanon

Lampada con montatura in metallo cromato, diffusore di luce in vetro triplex soffiato dai Maestri vetrai di Murano, pendagli in cristallo Swarovski trasparente.

Chrome plated frame, blown triplex shiny Murano glass, transparent Swarovski crystal pendants.

Lampe mit aufstellungim ChromMetall, Diffusor des Lichtes in geblasenem Glastriplex vom Meisterglaser von Murano. Anhänger im transparenten Swarovski Kristall.

Lampe avec monture en métal chromé, diffuseur de lumière en verre triplex soufflé par les maîtres vitriers de Murano, breloques en cristal Swarovski transparent.

Lámpara con montura en metal cromado, difusor de luz en vidrio soplado por los maestros vidrieros de Murano, colgantes en cristal Swarovski transparente.



Bianco lucido



Nero lucido

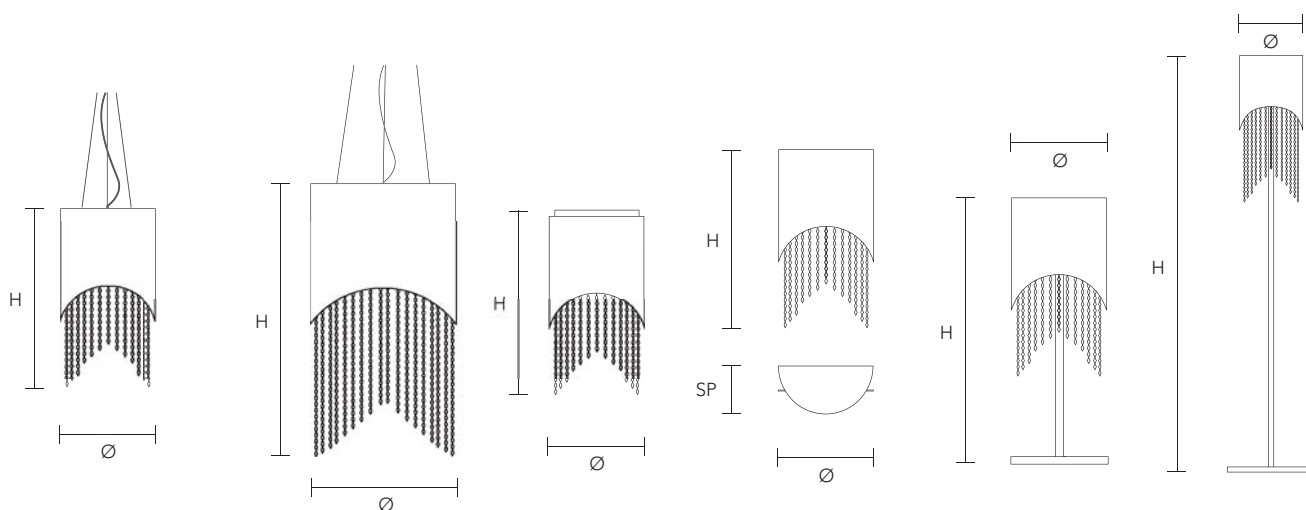

NEROSOLE S3 Ø24

H 43 cm
16.93"

Ø 24 cm
9.45"

W 3x40w



NEROSOLE S5 Ø36

H 60 cm
23.63"

Ø 36 cm
14.17"

W 5x40w



NEROSOLE PL3

H 46 cm
18.12"

Ø 24 cm
9.45"

W 3x40w



NEROSOLE A2

H 26 cm
10.24"

L 24 cm
9.45"

SP 12 cm
4.73"

W 2x40w



NEROSOLE TL3

H 60 cm
23.63"

Ø 24 cm
9.45"

W 3x40w



NEROSOLE STL3

H 180 cm
70.90"

Ø 24 cm
9.45"

W 3x40w





AÌSSI

Design by: Studio Stile Masiero



Aissi S5 Ø40





Aissi S1 Ø12

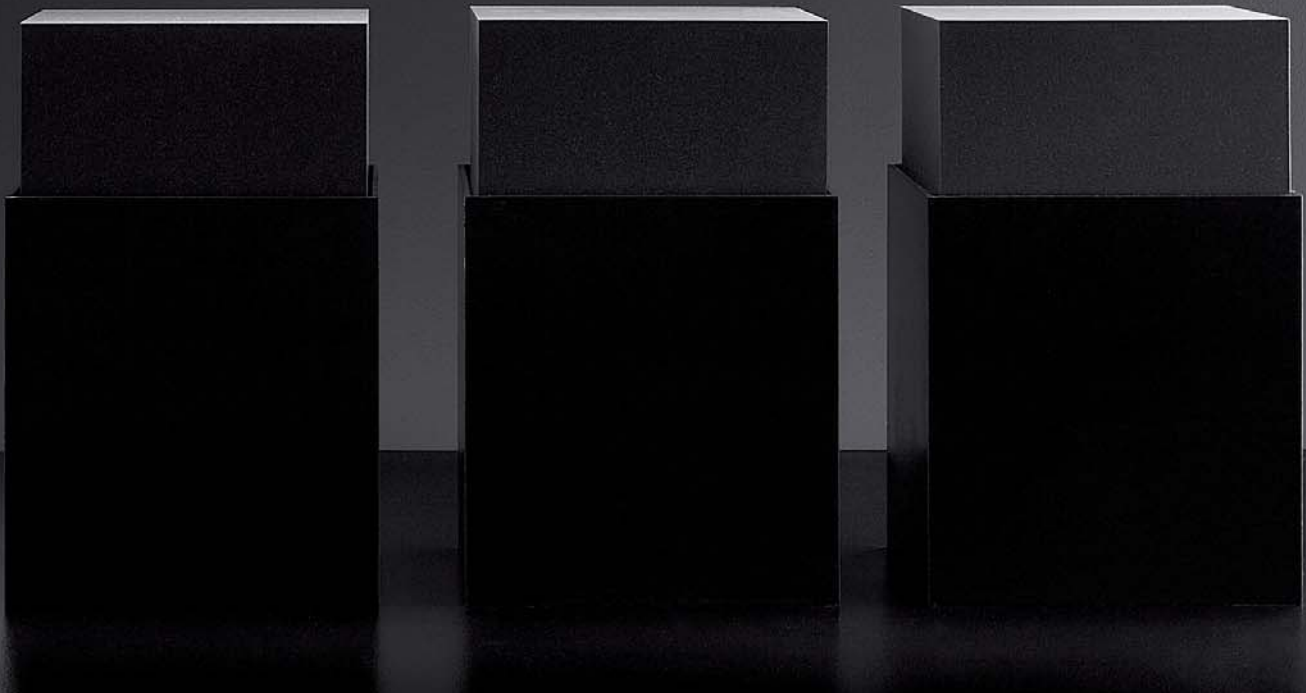



Aïssi PL1 Ø12



Aissi TL1 Ø12

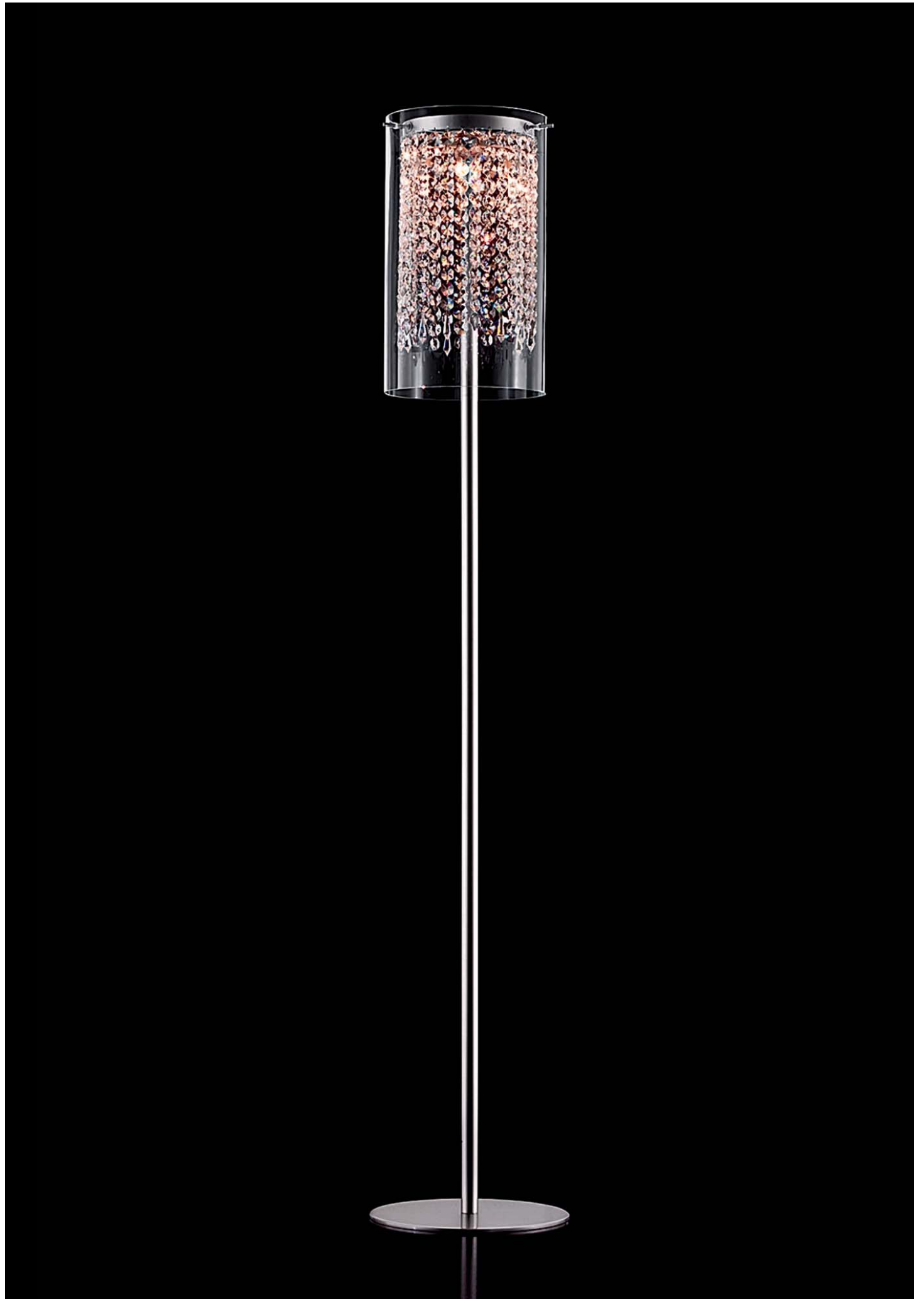

Aïssi STL3

AÏSSI

Design by: Studio Stile Masiero

Lampada con montatura in nikel opaco, pendagli in cristallo al 30% di piombo, diffusore di luce in vetro trasparente soffiato dai Maestri vetrai di Murano.

Dark nickel metal frame, lead crystal pendants 30% Pbo, transparent blown glass created by the Murano glass masters.

Lampe mit aufstellung im nikel matt, anhängen im Kristall bis 30%, diffusor des Lichtes in geblasenem transparentem Glas vom meisterglaser von Murano.

Lampe avec monture en nickel opaque, breloques en cristal à 30% de plomb, diffuseur de lumière en verre transparent soufflé par les maîtres vitriers de Murano.

Lámpara con montura en níquel opaco, colgante en cristal al 30% de plomo, difusor de luz en vidrio transparente soplado por los maestros vidrieros de Murano.

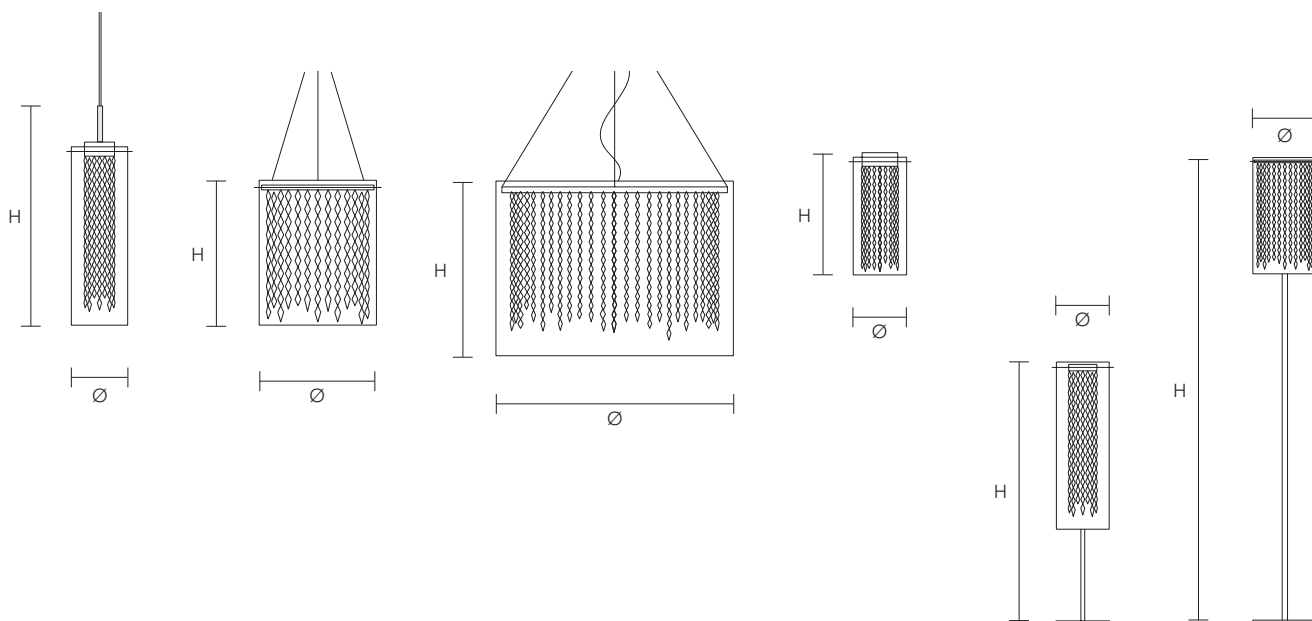

AÏSSI S1 Ø12

H 38 cm
14.97"

Ø 12 cm
4.73"

W 1x40w



AÏSSI S3 Ø24

H 30 cm
11.82"

Ø 24 cm
9.45"

W 3x40w



AÏSSI S5 Ø40

H 30 cm
11.82"

Ø 40 cm
15.75"

W 5x40w



AÏSSI PL1 Ø12

H 26 cm
10.24"

Ø 12 cm
4.73"

W 1x40w



AÏSSI TL1 Ø12

H 52 cm
20.48"

Ø 12 cm
4.73"

W 1x40w



AÏSSI STL3

H 180 cm
70.87"

Ø 24 cm
9.45"

W 3x40w







OBLÌO

Design by: Studio Stile Masiero



Oblio A2



Oblio S8



OBLÌO

Design by: Studio Stile Masiero

Lampade con montatura in vetro soffiato e lavorate a mano dai Maestri vetrai di Murano.

Hand made glass frame blown by the Murano glass master blowers.

Lampe mit aufstellung im geblasenem Glas und vom meisterglaser von Murano handgearbeitet.

Lampe avec monture en verre soufflé et travaillé à la main par les maîtres vitriers de Murano.

Lámpara con montura en vidrio soplado y trabajado a mano por los maestros vidrieros de Murano.

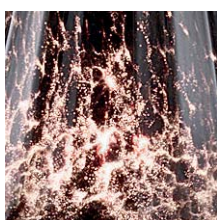

Vetro nero

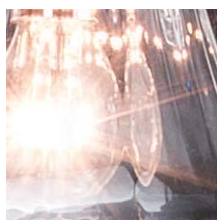

Vetro trasparente

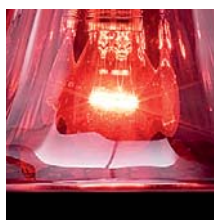

Vetro rosso

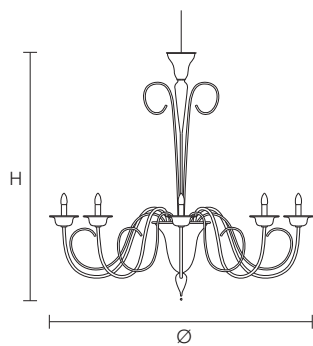
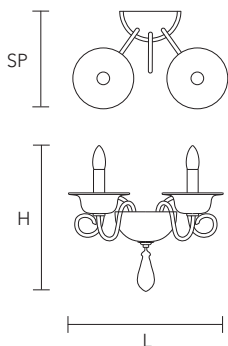

OBLÌO A2

H 38 cm
14.97"

L 42 cm
16.54"

SP 26 cm
10.24"

W 2x60w

 2xE14
Incandescenza

OBLÌO S8

H 75 cm
29.53"

Ø 115 cm
45.28"

W 8x60w

 8xE14
Incandescenza





VANTO

Design by: Fly Design Studio



Vanto TL1 G

Vanto TL1 P



Vanto STL1







Vanto A2

VANTO

Design by: Fly Design Studio

Lampada con montatura in ottone cromato, pendagli in cristallo al 30% di piombo, coppe in cristallo ottico.

Chrome plated brass frame, lead crystal pendants 30% Pbo, optic crystal plates.

Lampe mit aufstellung im Messing chromat anhängen im Kristall bis 30% von Blei, Becher im optischen Kristall.

Lampe avec monture en laiton chromé breloques en cristal à 30% de plomb, plateaux en cristal optique.

Lámpara con montura en latón cromado colgantes en cristal al 30% de plomo, copas en cristal óptico.



Paralume cotone nero



Paralume cotone bianco

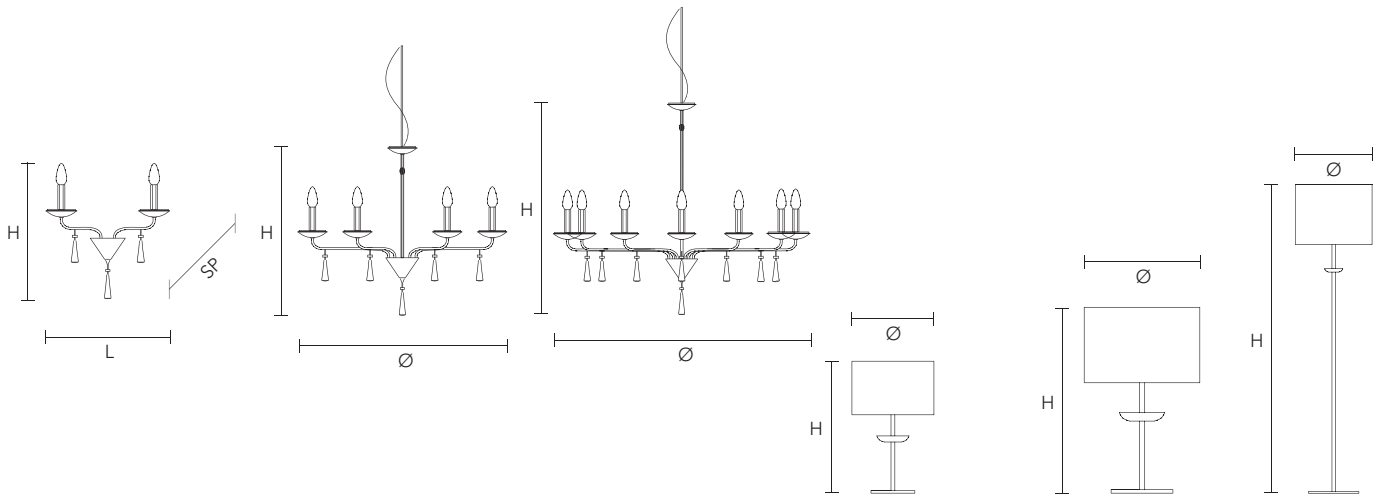

VANTO A2

H 46 cm
18.12"

L 42 cm
16.54"

SP 14 cm
5.52"

W 2x60w

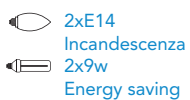

VANTO 6

H 60 cm
23.63"

Ø 75 cm
29.53"

W 6x60w

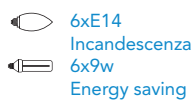

VANTO 12

H 78 cm
30.71"

Ø 95 cm
37.41"

W 12x60w

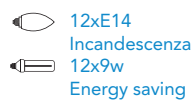

VANTO TL1 P

H 35 cm
13.78"

Ø 21 cm
8.27"

W 1x60w

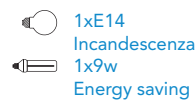

VANTO TL1 G

H 74 cm
29.14"

Ø 41 cm
16.15"

W 1x150w

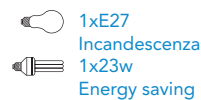

VANTO STL1

H 182 cm
71.66"

Ø 44.5 cm
17.52"

W 1x150w

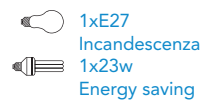

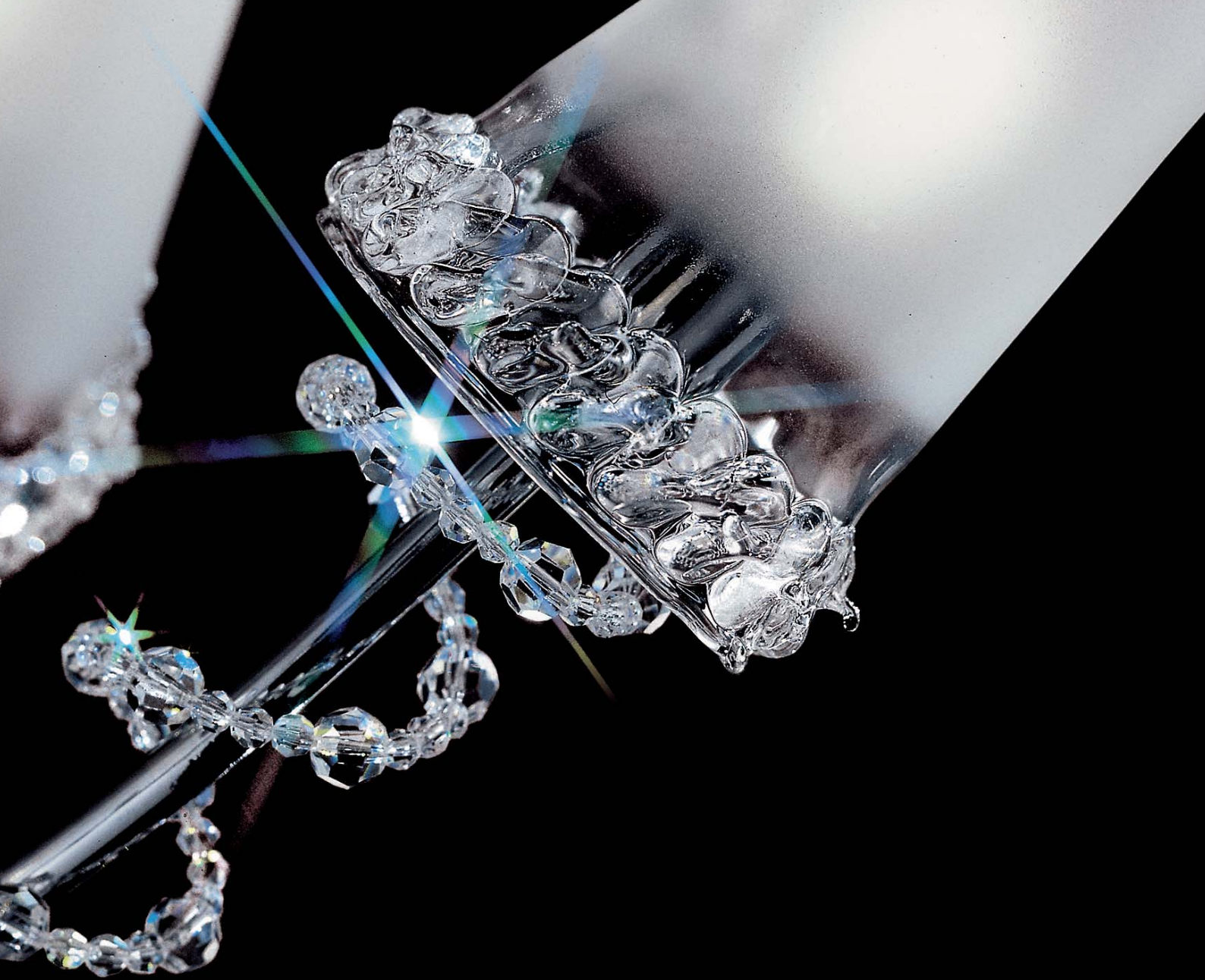

FANTASIA

Design by: Arianna Teardo



Fantasia A2



Fantasia S8



Fantasia PL6





Fantasia TL2

FANTASIA

Design by: Arianna Teardo

Lampada con montatura in ottone cromato, pendagli in cristallo al 30% di piombo, coppe in cristallo ottico.

Chrome plated brass frame, lead crystal pendants 30% Pbo, optic crystal plates.

Lampe mit aufstellung im Messing chromat anhängen im Kristall bis 30% von Blei, Becher im optischen Kristall.

Lampe avec monture en laiton chromé breloques en cristal à 30% de plomb, plateaux en cristal optique.

Lámpara con montura en latón cromado colgantes en cristal al 30% de plomo, copas en cristal óptico.

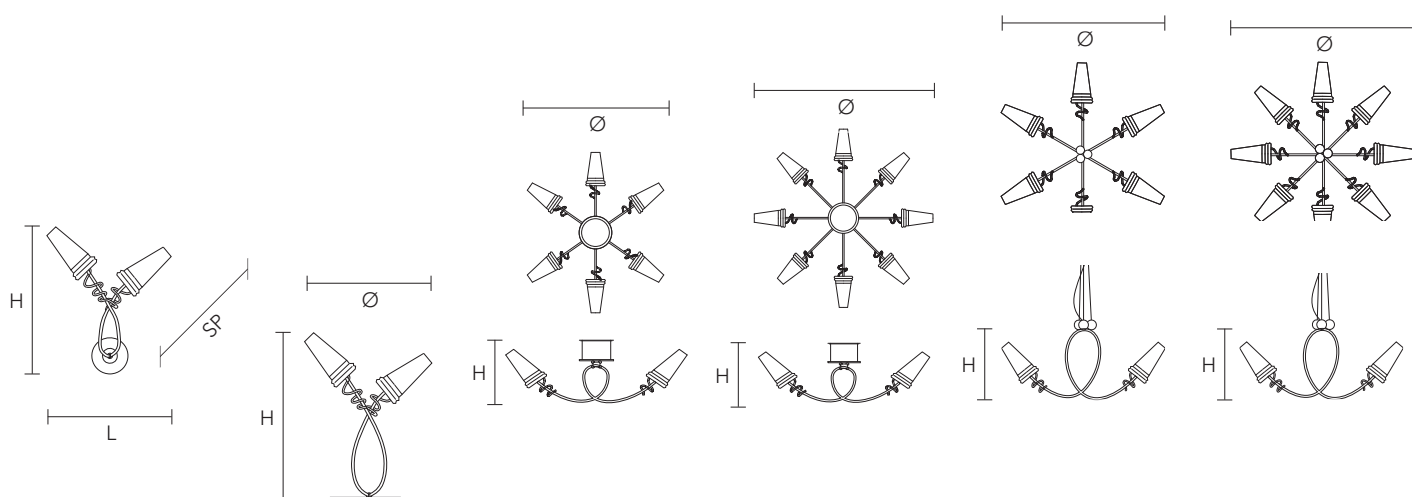

FANTASIA A2

H 43 cm
16.93"

L 33 cm
13.00"

SP 13 cm
5.12"

W 2x40w



FANTASIA TL2

H 48 cm
18.90"

Ø 30 cm
11.82"

W 2x40w



FANTASIA PL6

H 25 cm
9.85"

Ø 72 cm
28.35"

W 6x40w



FANTASIA PL8

H 25 cm
9.85"

Ø 90 cm
35.44"

W 8x40w



FANTASIA S6

H 30 cm
11.82"

Ø 72 cm
28.35"

W 6x40w



FANTASIA S8

H 30 cm
11.82"

Ø 90 cm
35.44"

W 8x40w





CLICK

Design by: Fly Design Studio







Click A1 RC



Click A1 RC

CLICK

Design by: Fly Design Studio

Lampada in acciaio inox AISI 304, pendaglio in cristallo Strass Swarovski trasparente.

Polished stainless steel frame AISI 304, transparent Strass Swarovski crystal pendant.

Lampe im rostfreien Stahl AISI 304, anhängen in Kristallstrass transparentes Swarovski.

Lampe en acier inoxydable AISI 304, breloques en cristal Strass Swarovski transparent.

Lámpara en acero inoxidable AISI 304, colgante en cristal Strass Swarovski transparente.

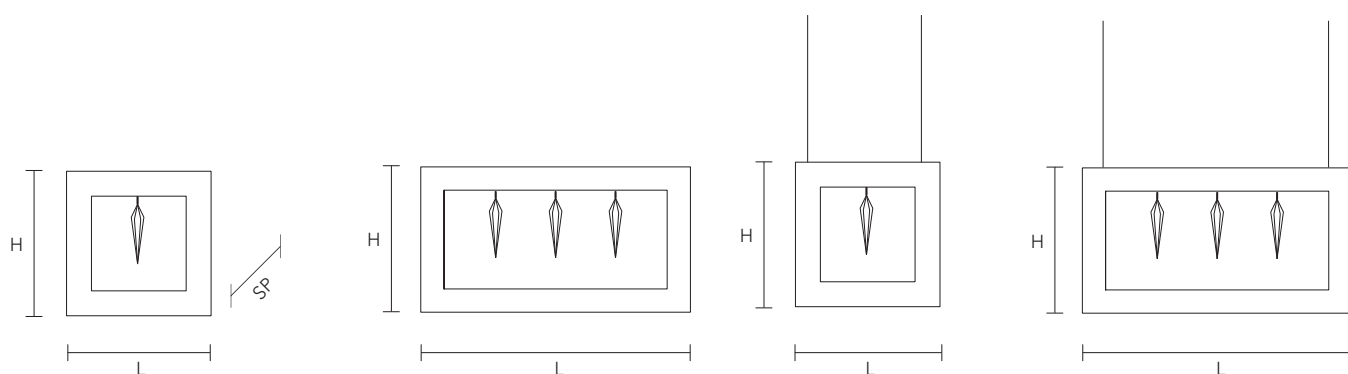

CLICK A1 SQ

H 29 cm
11.42"

L 29 cm
11.42"

SP 10 cm
3.95"

W 1x100w



CLICK A1 RC

H 29 cm
11.42"

L 58 cm
22.85"

SP 10 cm
3.95"

W 1x100w



CLICK S1 SQ

H 29 cm
11.42"

L 29x10 cm
11.42"x3.15"

W 1x150w



CLICK S1 RC

H 29 cm
11.42"

L 58x10 cm
22.85"x3.95"

W 1x150w



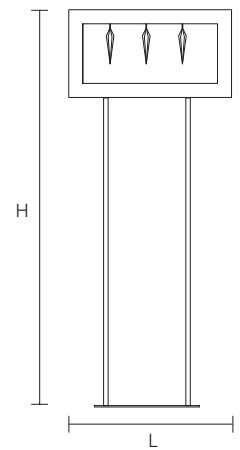
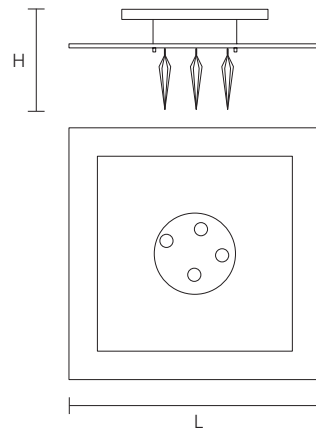
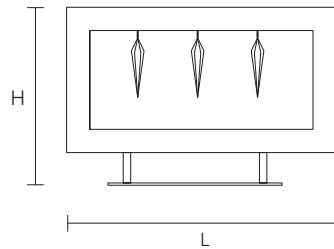
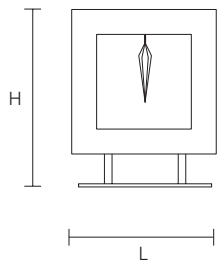

CLICK TL1 SQ

H 35 cm
13.78"
L 29x10 cm
11.42"x3.95"

W 1x150w



CLICK TL1 RC

H 35 cm
13.78"
L 58x10 cm
22.85"x3.95"

W 1x150w



CLICK PL4

H 29 cm
11.42"
L 62x62 cm
24.40"x24.40"

W 4x60w

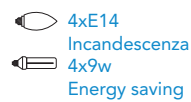

CLICK STL1

H 170 cm
66.90"
L 58x10 cm
22.85"x3.95"

W 1x150w





KLOK

Design by: Studio Stile Masiero



Klok S1 SQ



Klok S1 RC



Klok A1 RC

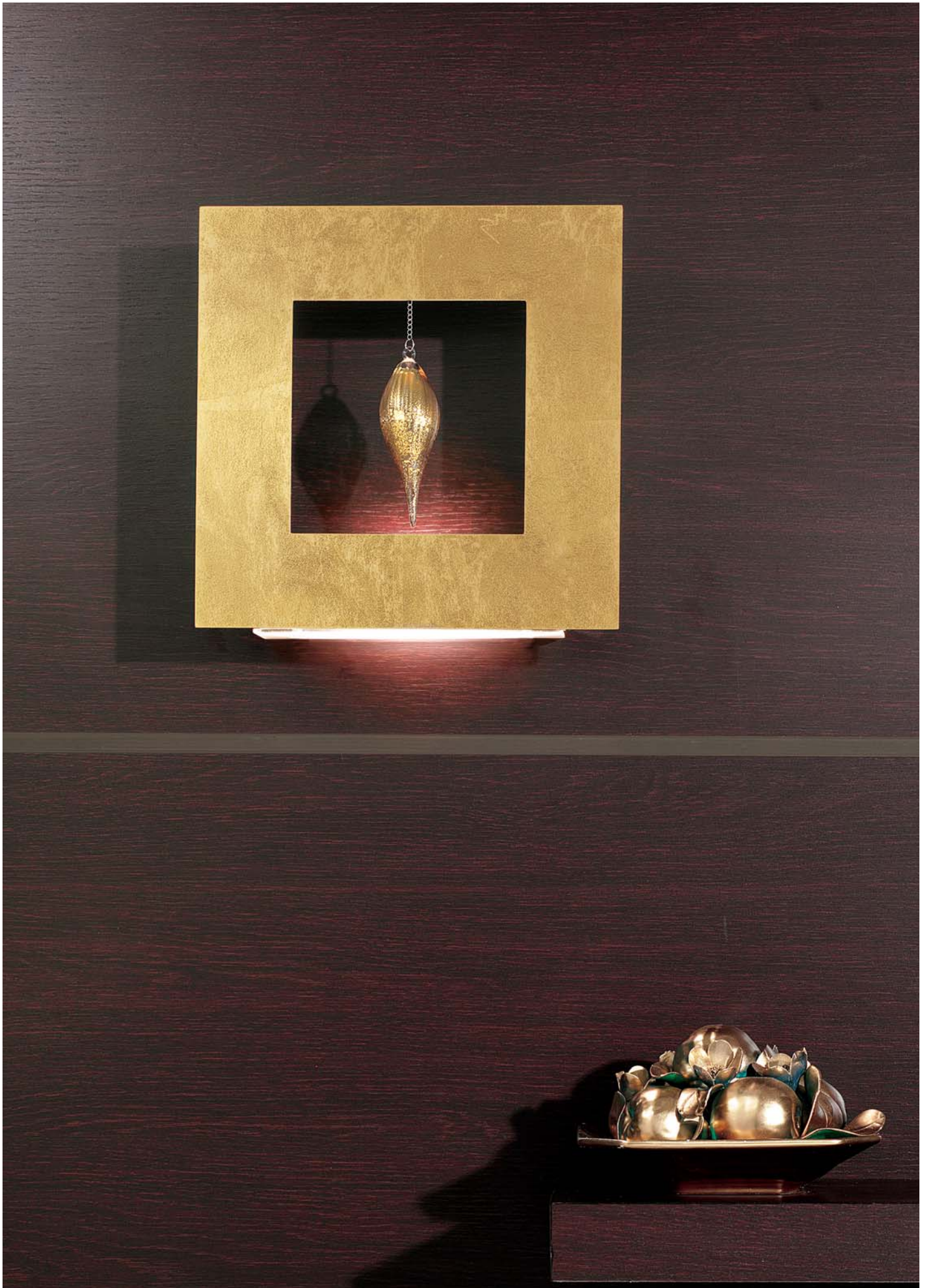

Klok A1 SQ



Klok TL1 SQ

Klok TL1 RC

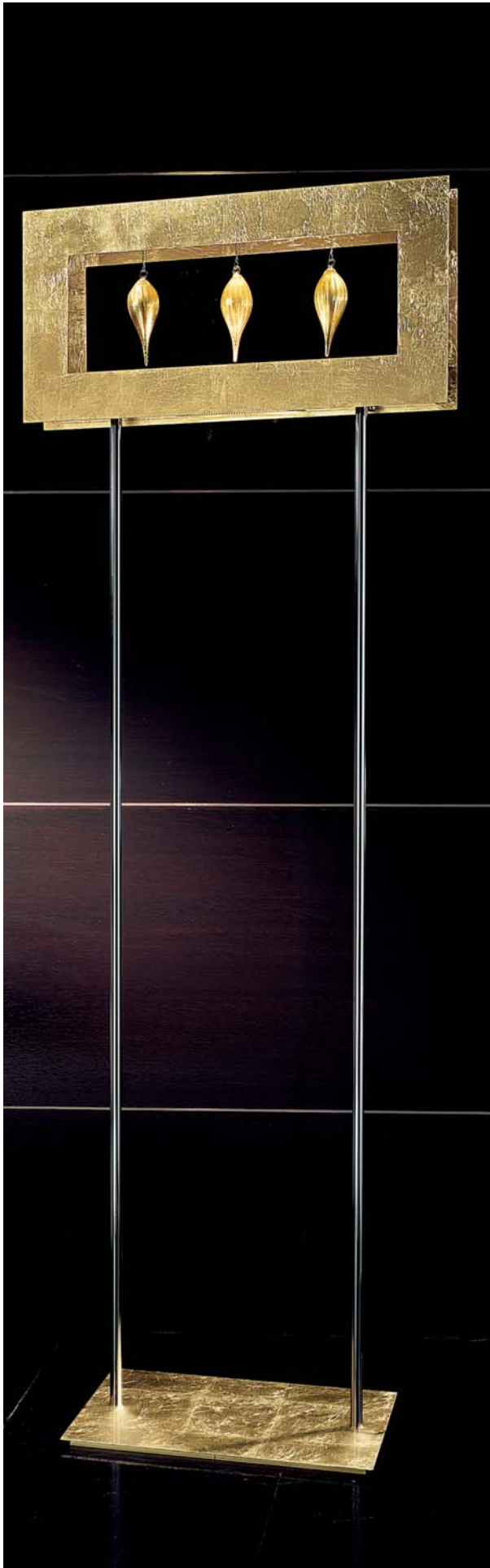

Klok STL1



Klok PL4

KLOK

Design by: Studio Stile Masiero

Telaio decorato con foglia oro, pendagli in vetro lavorato a mano e decorato foglia oro.

Gold leaf decorated metal frame, gold leaf hand made glass drops.

Mit Goldblatt dekorierte Fassung, Pendel aus handgearbeitetem Glas, mit Goldblatt dekoriert

Structure décorée avec des feuilles en or, des pendeloques en verre faites à la main et décorée avec des feuilles en or.

Estructura decorada con hoja de oro, colgantes de vidrio elaborado a mano y decorado con hoja de oro.

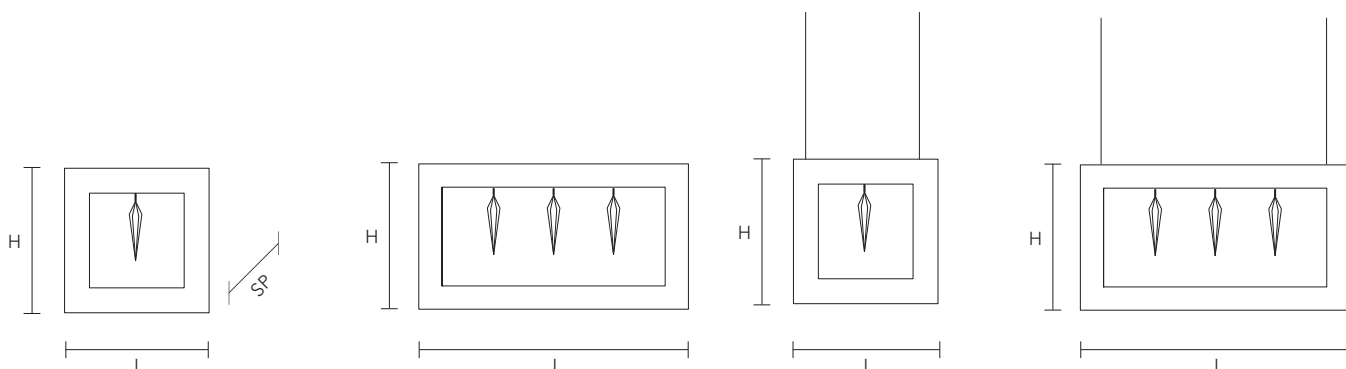

KLOK A1 SQ

H 29 cm
11.42"

L 29 cm
11.42"

SP 10 cm
3.95"

W 1x100w



KLOK A1 RC

H 29 cm
11.42"

L 58 cm
22.85"

SP 10 cm
3.95"

W 1x100w



KLOK S1 SQ

H 29 cm
11.42"

L 29x10 cm
11.42"x3.95"

W 1x150w



KLOK S1 RC

H 29 cm
11.42"

L 58x10 cm
22.85"x3.95"

W 1x150w



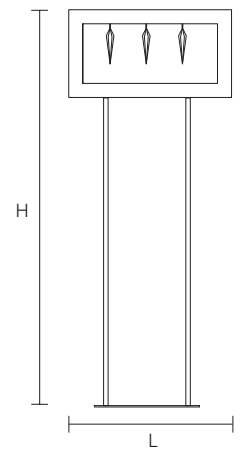
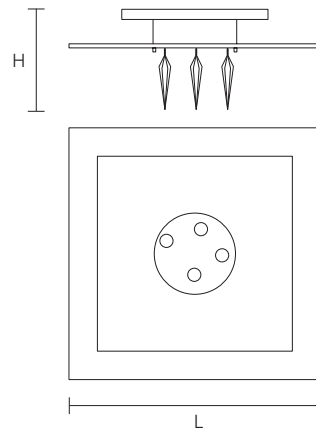
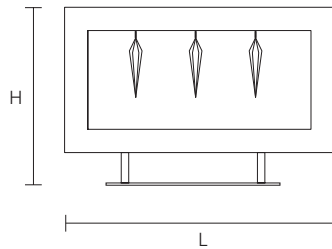
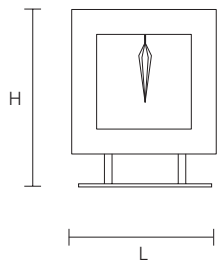

KLOK TL1 SQ

H 35 cm
13.78"
L 29x10 cm
11.42"x3.95"

W 1x150w



KLOK TL1 RC

H 35 cm
13.78"
L 58x10 cm
22.85"x3.95"

W 1x150w



KLOK PL4

H 29 cm
11.42"
L 62x62 cm
24.40"x24.40"

W 4x60w

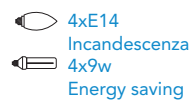

KLOK STL1

H 170 cm
66.90"
L 58x10 cm
22.85"x3.95"

W 1x150w





KASKÉ

Design by: Fly Design Studio



Kaské A1

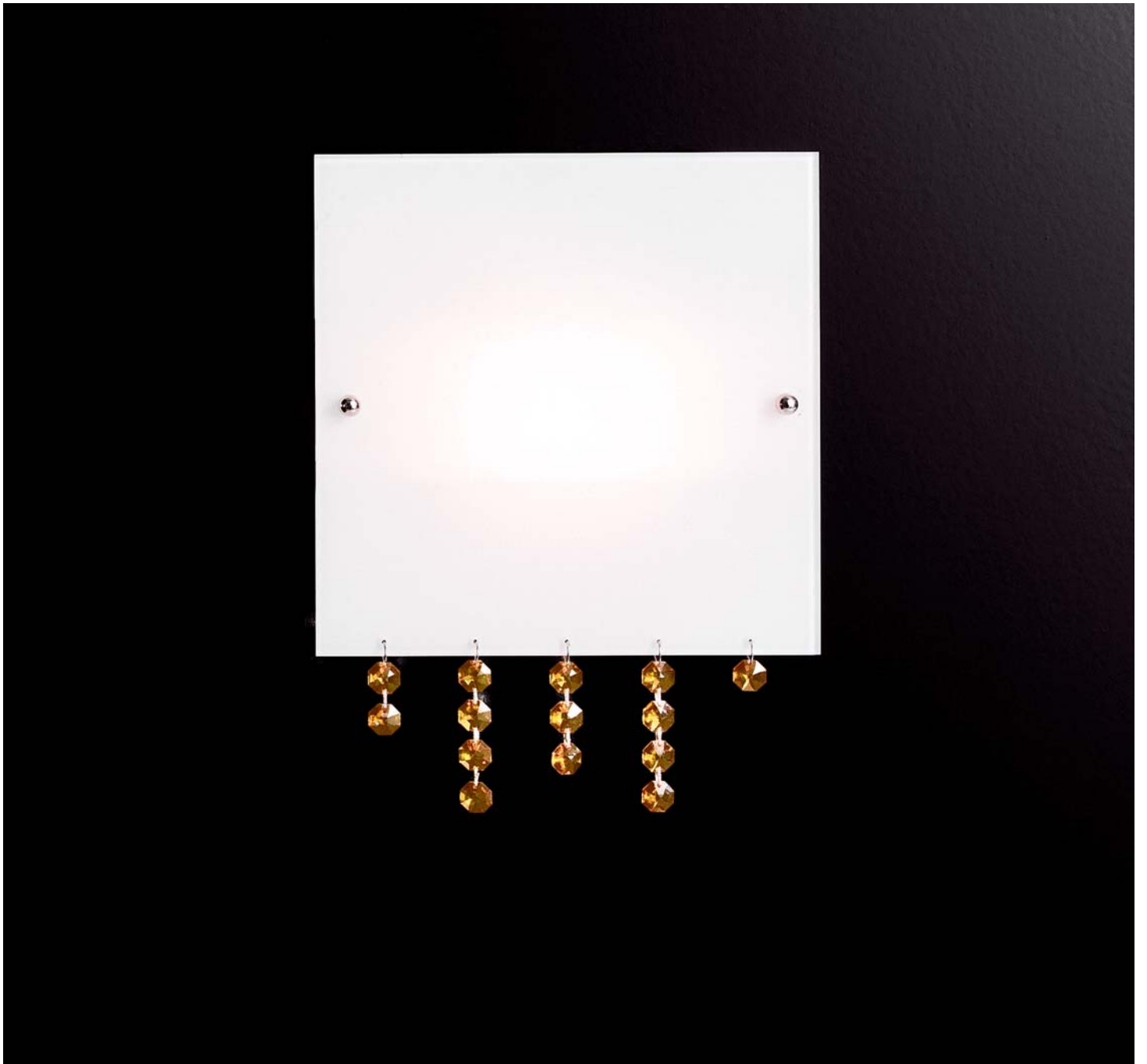



Kaské PL4



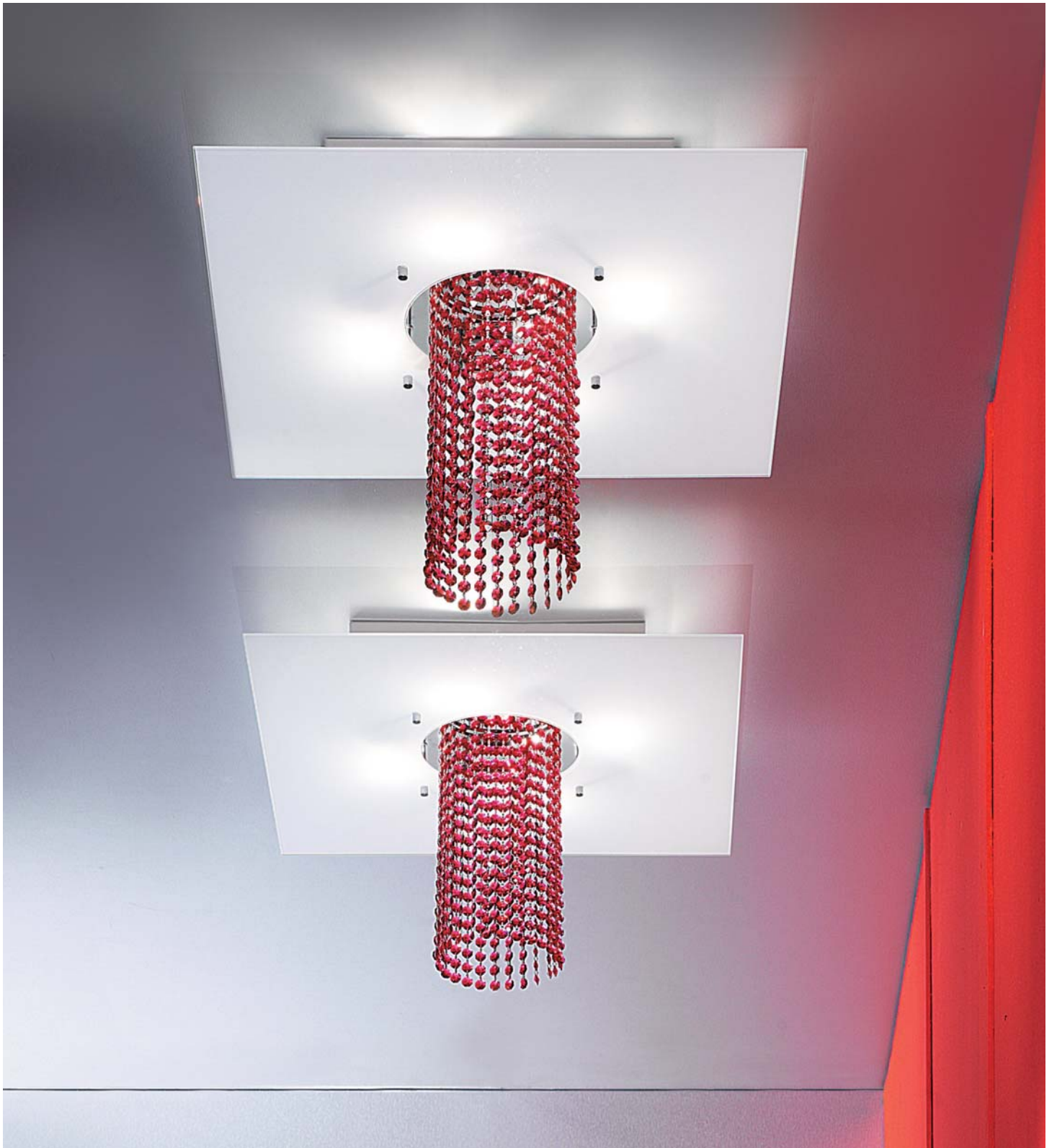

Kaské PL4

KASKÉ

Design by: Fly Design Studio

Lampada con montatura in metallo cromato, diffusore di luce in lastra di vetro bianco latte, pendagli in cristallo Strass Swarovski colorato.

Chrome plated metal frame, screen-printed opal white glass, coloured Strass Swarovski crystal pendants.

Lampe mit aufstellung im ChromMetall. Diffusor des Lichtes milch-weißen in der Glasplatte. Anhänger in Kristallstrass buntes Swarovski.

Lampe avec monture en métal chromé, diffuseur de lumière en plaque de verre blanc lait. Breloques en cristal Strass Swarovski teinté.

Lámpara con montura en metal cromado, difusor de luz en hoja de vidrio blanco leche. Colgantes en cristal Strass Swarovski coloreado.

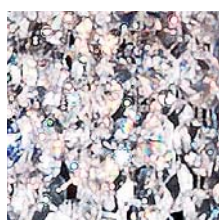

Trasparente



Saphire



Viola



Light Peridot

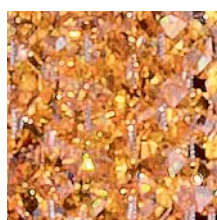

Ambra

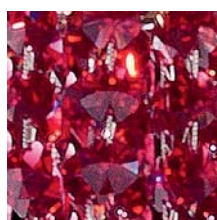

Rosso

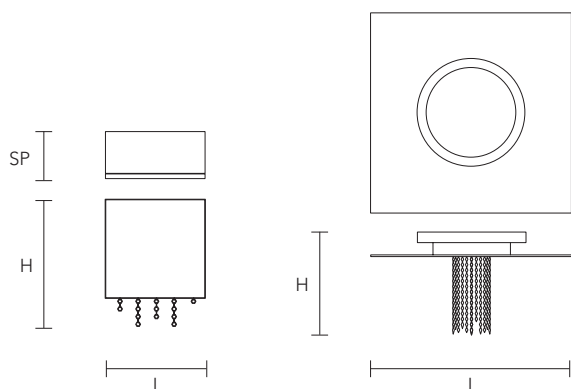

KASKÉ A1

H 30 cm
11.82"

L 22 cm
8.67"

SP 10 cm
3.94"

W 1x100w



KASKÉ PL4

H 38 cm
14.97"

L 60x60 cm
23.63"x23.63"

W 4x60w

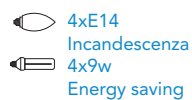





KIOCCIA

Design by: Studio Stile Masiero



Kioccia Lunga





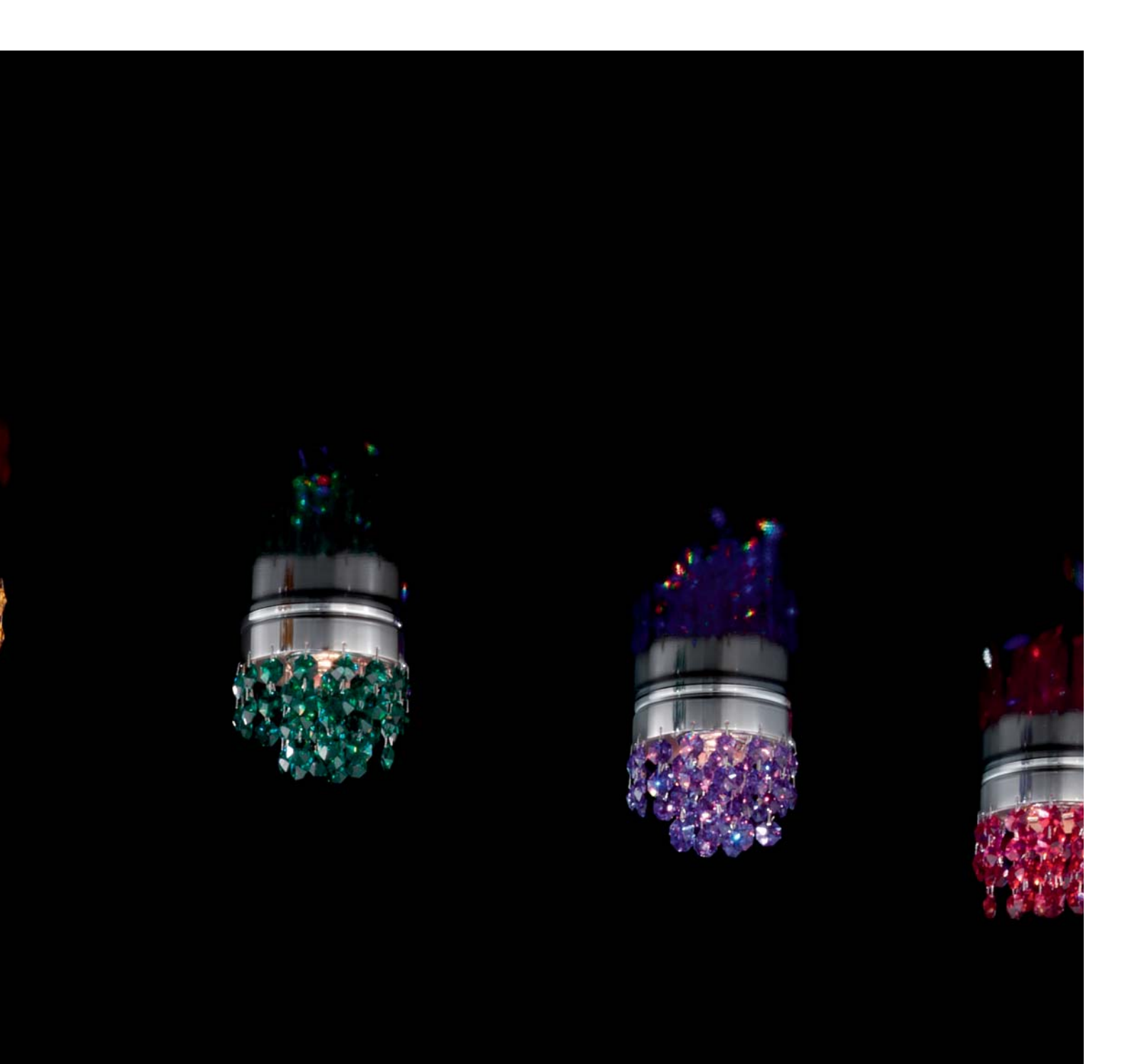



Kioccia PL1 C

Kioccia PL1 L

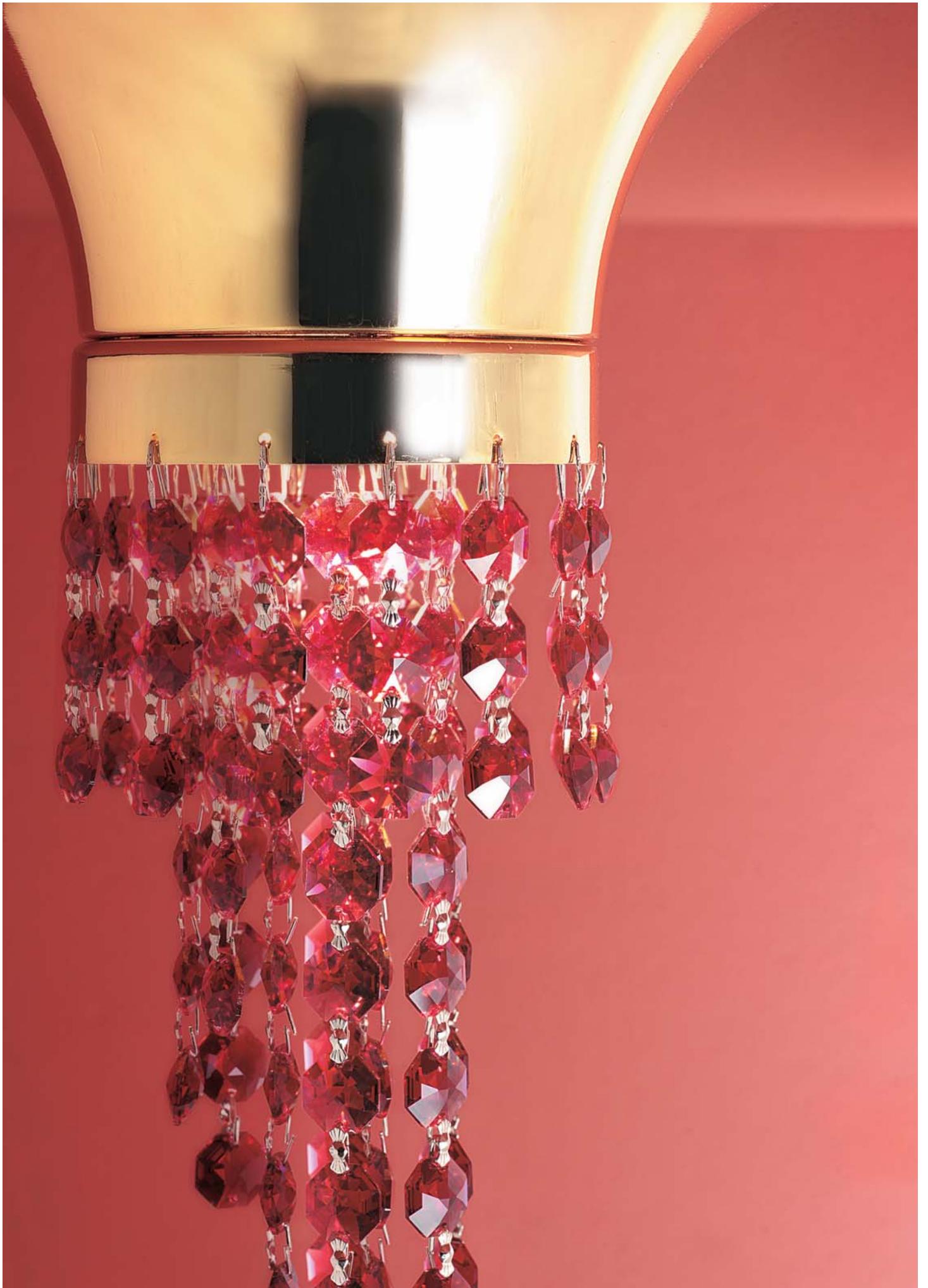



Kioccia S1

KIOCCIA

Design by: Studio Stile Masiero

Spot ad incasso e lampada con montatura in metallo cromato/d'orato, pendagli in cristallo Strass Swarovski colorato.

Chrome or gold plated recessed, ceiling light and suspension. Coloured Strass Swarovski crystal pendants.

Spot à encastrement et lampe avec monture en métal chromé/doré, pendeloques en cristal Strass Swarovski coloré.

Einbauspots und Leuchte mit Metallfassung Ausführung chrom/gold, Kristallpendel aus farbigen Strass Swarovski.

Foco empotrable y lámpara con cuerpo de metal cromado/dorado, colgantes de cristal Strass Swarovski colorado.



Trasparente

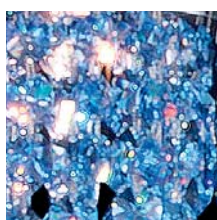

Saphire

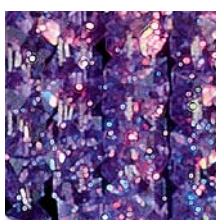

Viola



Light Peridot

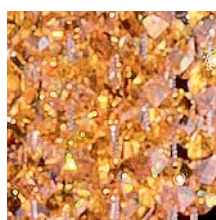

Ambra

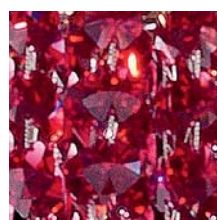

Rosso

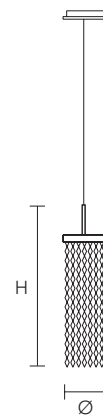
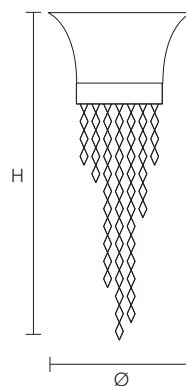
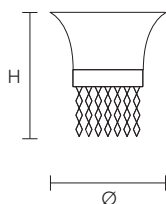
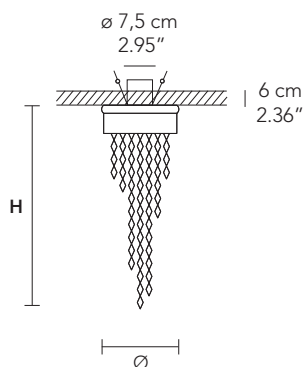
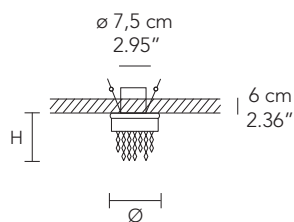

KIOCCIA CORTA

H 9 cm
3.55"

Ø 9 cm
3.55"

W 1x35w

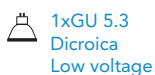

KIOCCIA LUNGA

H 25 cm
9.85"

Ø 9 cm
3.55"

W 1x35w

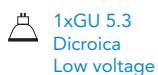

KIOCCIA PL1 C

H 15 cm
5.90"

Ø 16 cm
6.29"

W 1x50w



KIOCCIA PL1 L

H 35 cm
13.77"

Ø 16 cm
6.29"

W 1x50w



KIOCCIA S1

H 35 cm
13.77"

Ø 11 cm
4.33"

W 1x100w

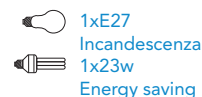



BALLOON

Design by: Fly Design Studio



Baloon TL3



Baloon S3



Baloon TL3

BALOON

Design by: Fly Design Studio

Lampada con montatura in metallo verniciato, diffusore di luce in vetro triplex di Murano soffiato.

Lamp with painted metal frame and light diffuser in blown triplex Murano glass.

Leuchte mit Gestell aus lackiertem Metall, Lichtdiffuser aus geblasenem Murano Triplexglas.

Lampe avec monture en métal verni, diffuseur de lumière en verre triplex de Murano soufflé.

Lámpara con montura de metal barnizado, difusor de luz de cristal triplex de Murano soplado.



Nero/Bianco



Bianco/Bianco

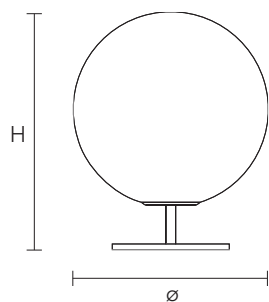
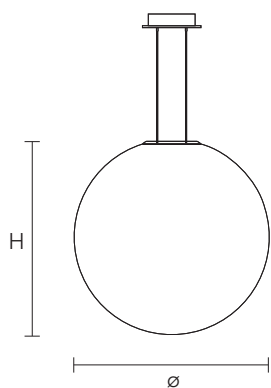

BALOON S3

H 45 cm
17.70"

Ø 50 cm
19.70"

W 3x75w

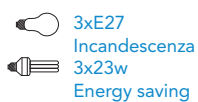

BALOON TL3

H 61 cm
24.00"

Ø 50 cm
19.70"

W 3x75w

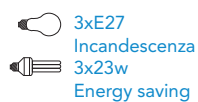



FLUTÉ

Design by: Crepax-Zanon





Fluté S1



Fluté BIN3



Fluté A1



Fluté PL1 P



Fluté PL1 P



Fluté S1 P

FLUTÉ

Design by: Crepax-Zanon

Lampada con montatura in metallo cromato, diffusore di luce in vetro triplex di Murano soffiato.

Lamp with chromeplated metal frame and light diffuser in blown triplex Murano glass.

Leuchte mit Gestell aus verchromtem Metall, Lichtdiffuser aus geblasenem Murano-Triplexglas.

Lampe avec monture en métal chromé, diffuseur de lumière en verre triplex de Murano soufflé.

Lámpara con montura de metal cromado, difusor de luz de cristal triplex de Murano soplado.

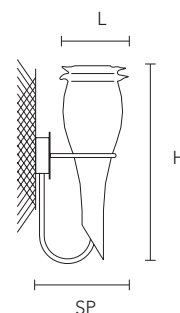
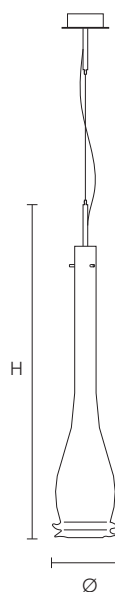
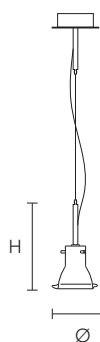
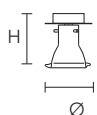

FLUTÉ PL1 P

H 14 cm
5.51"

Ø 14 cm
5.51"

W 1x40w



FLUTÉ S1 P

H 24 cm
9.45"

Ø 14 cm
5.51"

W 1x40w



FLUTÉ S1

H 90 cm
35.44"

Ø 17 cm
6.70"

W 1x60w

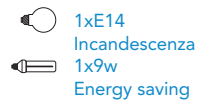

FLUTÉ A1

H 50 cm
19.70"

L 17 cm
6.70"

SP 24 cm
9.45"

W 1x60w

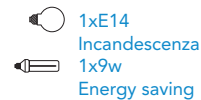



Bianco



Trasparente

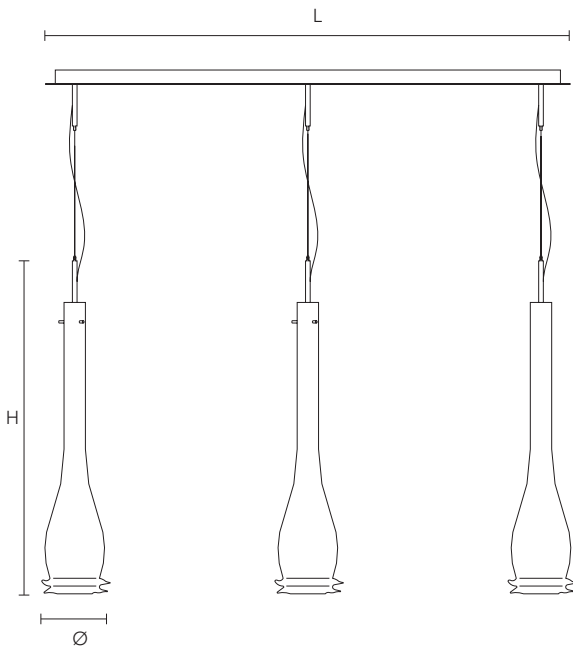
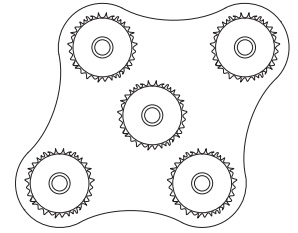
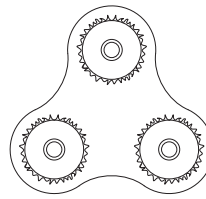



FLUTÉ BIN3

H 90 cm
35.44"

L 135 cm
53.15"

Ø 17 cm
6.70"

W 3x60w

-  3xE14
Incandescenza
-  3x9w
Energy saving

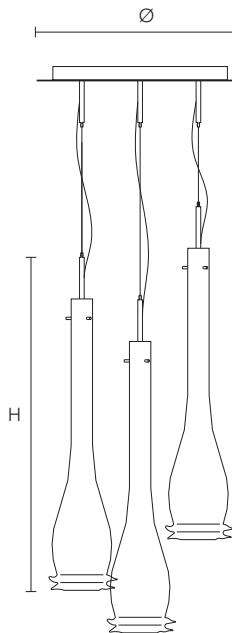



FLUTÉ S3

H 90 cm
35.44"

Ø 55 cm
21.65"

W 3x60w

-  3xE14
Incandescenza
-  3x9w
Energy saving

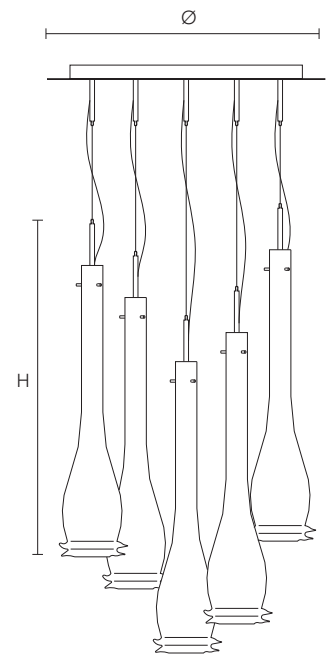



FLUTÉ S5

H 90 cm
35.44"

Ø 80 cm
31.50"

W 5x60w

-  5xE14
Incandescenza
-  5x9w
Energy saving





AUREA

Design by: Studio Stile Masiero





Aurea_35 S5





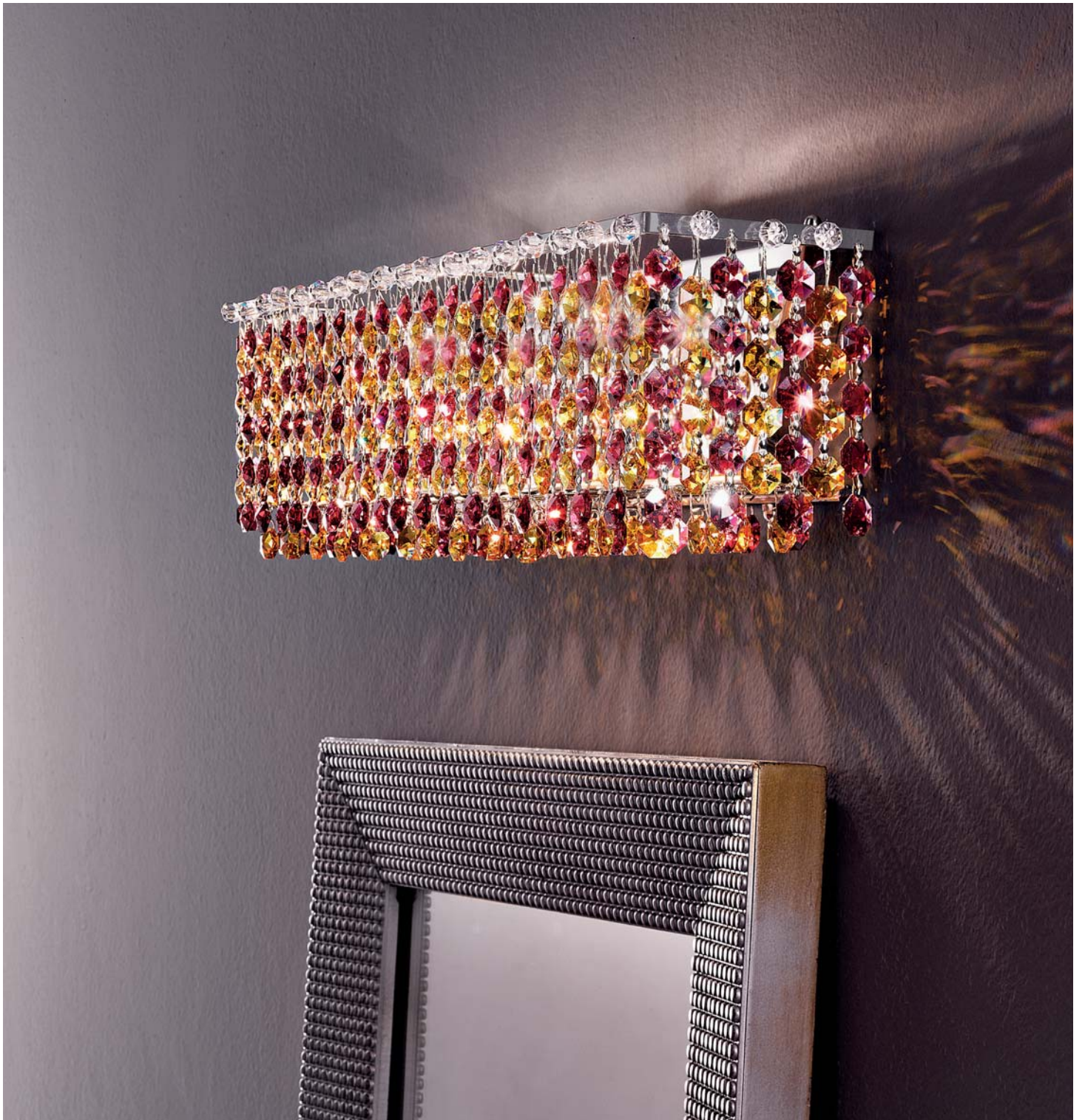



Aurea_10 S1







Aurea_15 TL1

Aurea_10 TL1



Aurea_55 PL6



Aurea_55 PL6

AUREA

Design by: Studio Stile Masiero

Lampada con montatura in metallo cromato/d'orato, pendagli in cristallo Strass Swarovski colorato.

Chrome or gold plated ceiling light and suspension. Coloured Strass Swarovski crystal pendants.

Lampe avec monture en métal chromé/doré,pendeloques en cristal Strass Swarovski coloré.

Leuchte mit Metallfassung Ausführung chrom/gold, Kristallpendel aus farbigen Strass Swarovski.

Lámpara con cuerpo de metal cromado/dorado, colgantes de cristal Strass Swarovski colorado.

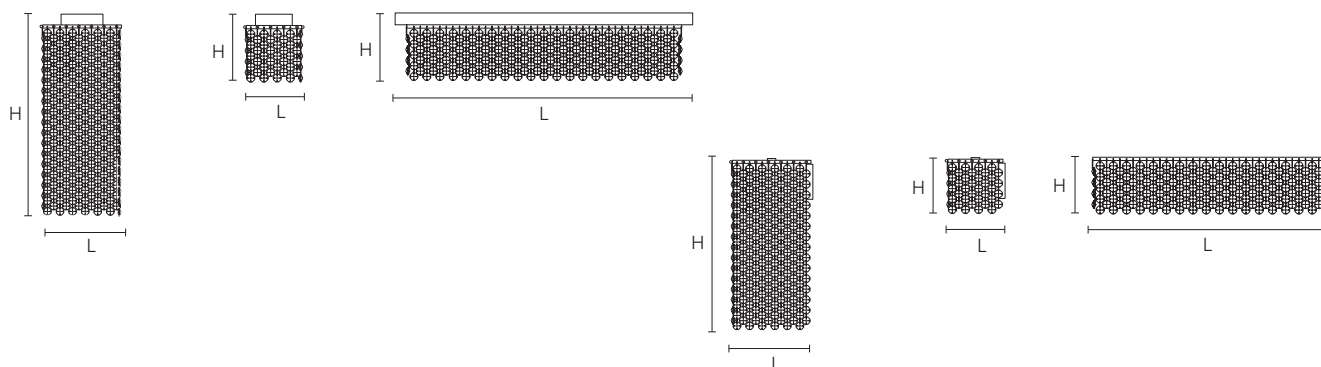



AUREA_15 PL1

H 30 cm
12"

L 15x15 cm
5.91"x5.91"

W 1x100w

 1xE27 Incandescenza
 1x23w Energy saving



AUREA_10 PL1

H 12 cm
4.73"

L 10x10 cm
3.95"x3.95"

W 1x40w

 1xG9 Alogena



AUREA_55 PL6

H 13 cm
5.12"

L 55x55 cm
21.65"x21.65"

W 6x40w

 6xG9 Alogena





AUREA_15 A1

H 30 cm
11.80"

L 15x15 cm
5.91"x5.91"

SP 16 cm
6.30"

W 1x100w

 1xE27 Incandescenza
 1x23w Energy saving



AUREA_10 A1

H 10 cm
3.94"

L 10 cm
3.95"

SP 11 cm
4.33"

W 1x40w

 1xG9 Alogena



AUREA_40 A2

H 10 cm
3.94"

L 40 cm
15.76"

SP 10 cm
3.95"

W 2x40w

 2xG9 Alogena





Trasparente

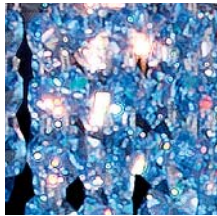

Saphire

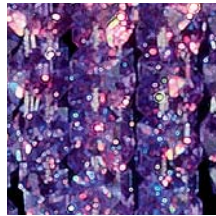

Viola

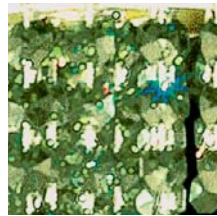

Light Peridot

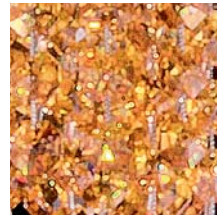

Ambra

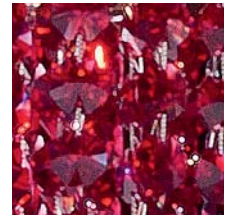

Rosso

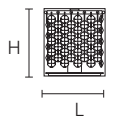
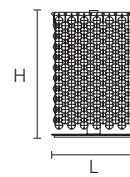
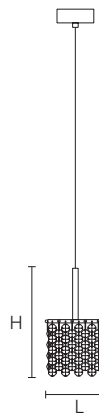
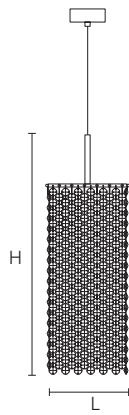
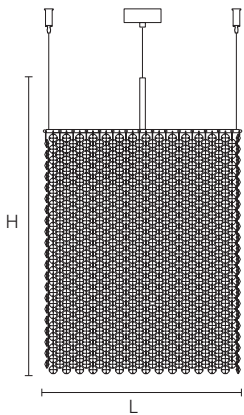

AUREA_35 S5

H 55 cm
21.65"

L 35x35 cm
13.80"x13.80"

W 5x100w

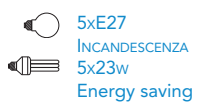

AUREA_15 S1

H 37 cm
14.80"

L 15x15 cm
5.91"x5.91"

W 1x100w

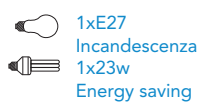

AUREA_10 S1

H 20 cm
7.90"

L 10x10 cm
3.95"x3.95"

W 1x40w



AUREA_15 TL1

H 24 cm
9.45"

L 15x15 cm
5.91"x5.91"

W 1x100w

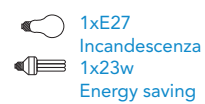

AUREA_10 TL1

H 13 cm
5.12"

L 10x10 cm
3.95"x3.95"

W 1x40w



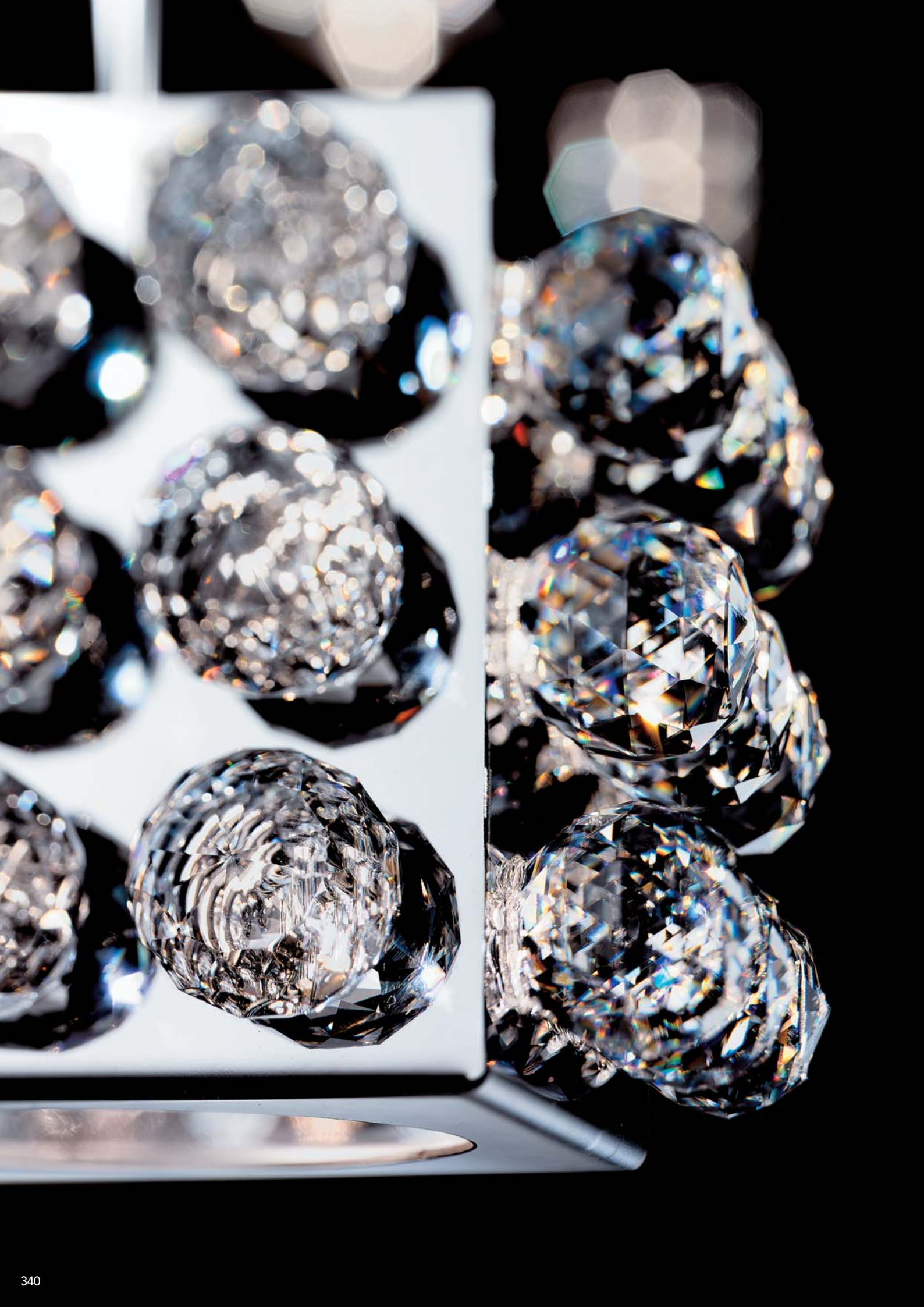

CUBIX

Design by: Studio Stile Masiero



Cubix PL1





Cubix S1





Cubix A1

CUBIX

Design by: Studio Stile Masiero

Lampada in acciaio
inox AISI 304.
Cristallo Strass
Swarovski trasparente.

Polished stainless
steel frame AISI 304.
Transparent Strass
Swarovski crystal.

Lampe im rostfreien
Stahl AISI 304,
anhänger in Kristallstrass
transparentes Swarovski.

Lampe en acier
inoxidable AISI 304.
Cristal Strass Swarovski
transparent.

Lámpara en acero
inoxidable AISI 304.
Cristal StrassSwarovski
transparente.

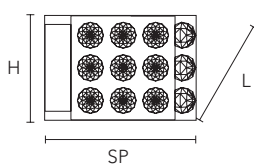
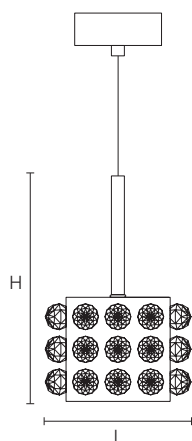
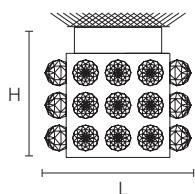

CUBIX PL1

H 10 cm
3.95"

L 12 x 12 cm
4.73"x 4.73"

W 1x60w



CUBIX S1

H 18 cm
7.10"

L 12 x 12 cm
4.73"x 4.73"

W 1x60w



CUBIX A1

H 8 cm
3.15"

L 12 cm
4.73"

SP 16
6.30"

W 1x60w





ATTESTA LA CONFORMITÀ DEL PRODOTTO ALLE DISPOSIZIONI DELLE DIRETTIVE COMUNITARIE.

IT CERTIFIES THE CONFORMITY OF THE PRODUCTS TO THE EUROPEAN COMMUNITY PROVISIONS.

IL ATTESTE LA CONFORMITÉ DU PRODUIT AUX DISPOSITIONS DES DIRECTIVES COMMUNITAIRES.

KONFORMITÄ DES PRODUKTES MIT DEN RICHTLINIEN DER EUROPÄISCHEN GEMEINSCHAFT.

ESTA CERTIFICA SI EL PRODUCTO ES CONFORME A LAS DISPOSICIONES DE LAS NORMAS DE LA COMUNIDAD ECONÓMICA EUROPEA.

CLASSE DI ISOLAMENTO CLASSE I. APPARECCHI PROVVISI DI ISOLAMENTO FONDAMENTALE IN OGNI PARTE E CON PARTI CONDUTTRICI ACCESSIBILI COLLEGATE AD UN CONDUTTORE SUPPLEMENTARE DI PROTEZIONE (MESSA A TERRA).

DOVE NON SPECIFICATO DIVERSAMENTE, SI INTENDE CLASSE I.

CLASS I. APPLIANCE FITTED WITH BASIC INSULATION THROUGHOUT AND WITH ACCESSIBLE LIVE PARTS CONNECTED TO A SUPPLEMENTARY SAFETY CIRCUIT (GROUND). WHERE NOT EXPRESSLY SPECIFIED, IT IS UNDERSTOOD: CLASS I.

CLASSE I. C'EST-À-DIRE APPAREIL DOTÉ D'ISOLATION FONDAMENTALE DANS TOUTES SES PARTIES ET DONT LES PIÈCES CONDUCTRICES ACCESSIBLES SONT RELIÉES À UN CONDUCTEUR (MISE À LA TERRE). OÙ N'EST PAS EXPRESSÉMENT SPECIFIÉ, ON DOIT S'ENTENDRE: PREMIÈRE CLASSE.

KLASSE I, BZW. AN ALLEN TEILEN ISOLIERTES GERÄT MIT ZUGÄNGLICHENLEITENDEN TEILEN, DIE AN EINEN ZUSÄTZLICHEN SCHUTZLEITER ANGESCHLOSSEN SIND (ERDUNG). WO NICHT ERKLÄRT, VERSTEHT ES SICH: ERSTE KLASSE.

PRIMERA CLASE. ESTO ES APARATO PROVISTO DE AISLAMIENTO FUNDAMENTAL ENTODAS SUS PARTES Y CON PARTES CONDUCTORAS ACCESIBLE, CONEXIONADAS CON CONDUCTOR SUPLEMENTARIO DE PROTECCIÓN (TORNA DE TIERRA). DÓNDE NE ES ESPECIFICADO EXPRESAMENTE SE ENTENDE LA PRIMERA CLASE.



CLASSE DI ISOLAMENTO CLASSE II. CON DOPPIO ISOLAMENTO E/O RINFORZO IN OGNI PARTE E SENZA DISPOSITIVI PER LA MESSA A TERRA.

CLASS OF INSULATIONS CLASS II. APPLIANCE FITTED WITH DOUBLE INSULATION OR REINFORCED INSULATION WITHOUT GROUND CONNECTION.

DEGRÉ LA PROTECTION II. APPAREIL AVEC DOUBLE ISOLATION OU RENFORCE, SANS MISE À LA TERRE. SCHUTZKLASSE II. LEUCHTE MIT DOPPELTER UND/ODER VERSTÄRKTER ISOLIERUNG, OHNE ERDUNG.

CLASE DE AISLAMIENTO CLASE II. CON DOBLE AISLAMIENTO Y/O AISLAMIENTO REFORZADO EN CADA PARTE Y SIN DISPOSITIVO DE TOMA DE TIERRA.



CLASSE DI ISOLAMENTO CLASSE III. APPARECCHI CON PROTEZIONE BASATA SULL'ALIMENTAZIONE A BASSA TENSIONE.

CLASS III. THE SAFETY OF THE FIXTURE IS PROVIDED WITH A LOW-VOLTAGE CIRCUIT DEVICE.

TOISIÈME CLASSE. OU BIEN APPAREIL AVEC PROTECTION BASÉE SUR L'ALIMENTATION À TRÈS BASSE TENSION DE SÉCURITÉ.

DRITTE KLASSE. ODER AUCH GERÄT MIT SCHUTZ, DER AUF EINE SEHR NIEDRIGE SCHUTZSPANNUNGSZUFÜHRUNG GEGRÜNDET IST.

TERCERA CLASE. APARATO CON PRODUCCIÓN SUSTENTADA EN ALIMENTACIÓN A BAJA TENSIÓN DE SEGURIDAD.



APPARECCHIO ADATTO AL MONTAGGIO SU SUPERFICI NORMALMENTE INFIAMMABILI.

SUITABLE FOR MOUNTING ON NONE-FIREPROOF.

APPAREIL PRÉVU POUR UN MONTAGE DIRECT SUR DES SURFACES NORMALEMENT INFLAMMABLES.

KONFORMITÄT DES PRODUKTES MIT DEN RICHTLINIEN DER EUROPÄISCHEN GEMEINSCHAFT. LEUCHTE MIT BRANDSCHUTZ.

APARADO PARA COLOCAR DIRECTAMENTE SOBRE SUPERFICIES INFLAMABLES.



APPARECCHIO NON
ADATTO AL MONTAGGIO SU
SUPERFICI NORMALMENTE
INFIAMMABILI.

THIS EQUIPMENT IS NOT
SUITABLE FOR MOUNTING
ON NONE-FIREPROOF.

L'APPAREIL NE PEUT PAS
PRÉVU POUR UN
MONTAGE DIRECT SUR DES
SURFACES NORMALEMENT
INFLAMMABLES.

GERÄT NICHT FÜR EINE
MONTAGE AUF NORMALER-
WEISE ENTFLAMMBAREN
OBERFLÄCHEN
GEEIGNET.

APARATO NO APROPIADO
PARA COLOCAR
DIRECTAMENTE SOBRE
SUPERFICIES INFLAMABLES.

EMME PI LIGHT - MASIERO SI RISERVA IL
DIRITTO DI APPORTARE AI PROPRI MODELLI,
SENZA NESSUN PREAVVISO, QUALSIASI MODI-
FICA RITENESSE OPPORTUNA.

EMME PI LIGHT - MASIERO RESERVES THE
RIGHT TO INTRODUCE ANY CHANGES TO
ITS OWN MODELS, WITHOUT NOTICE IN
ADVANCE.

EMME PI LIGHT - MASIERO BEHALT SICH DAS
RECHT VOR ÄNDERUNGEN VORZUNEHMEN,
OHNE SOFORTIGE BENACHRICHTIGUNG.

EMME PI LIGHT - MASIERO SE RÉSERVE LE
DROIT D'APPORTER UNE QUELCONQUE
MODIFICATION À LES MODÈLES SANS
PRÉAVIS.

EMME PI LIGHT - MASIERO SE RESERVA EL
DERECHO DE REALIZAR CUALQUIER MODI-
FICACIÓN SOBRE SUS MODELOS SIN PREVIO
AVISO.

MASIERO[®]



Masiero disegna e realizza interamente nel proprio opificio lampade eclettiche, dal tradizionale stile veneziano fino al design contemporaneo. L'elemento di continuità è la forte personalità di ogni opera firmata Masiero.

Entirely in his own workshop, Masiero designs and creates lamps of different styles from the traditional Venetian style to contemporary design. The element of continuity is a strong characteristic of every work made by Masiero.

Masiero conçoit et réalise entièrement dans son usine des lampes électriques de styles différents, du style vénitien traditionnel au design contemporain. L'élément de continuité est constitué par la forte personnalité de chaque œuvre signée Masiero.

Masiero diseña y realiza por completo en su propia fábrica lámparas eclécticas, del tradicional estilo veneciano al diseño contemporáneo. El elemento de continuidad es la fuerte personalidad de cada obra firmada Masiero.

Masiero entwirft und konstruiert in ihrem Werk vielseitige Lampen, vom traditionellen venezianischen Stil bis hin zum zeitgemäßen Design. Das kontinuierliche Element besteht in der starken Persönlichkeit jeder einzelnen Kreation von Masiero.



MASIERO®

EMME PI LIGHT - MASIERO S.R.L. VIA PESCHIERE, 53
31032 LOC. CONSCIO DI CASALE SUL SILE (TREVISO) ITALY
TEL. +39 0422 7861 FAX +39 0422 786250

info@masierogroup.com

www.masierogroup.com



Reg. n. 6450-A
Norma ISO 9001:2008

Ogni riproduzione anche parziale è vietata.
© by Masiero 2011
Tutti i diritti riservati.

Any reproduction even partial is strictly prohibited.
© by Masiero 2011
All rights reserved.

Art direction: GIOVANNI BATTISTA GIANOLA

Design by: ARGINE

Copywriter: MARIO MARANGON

Print: GRAFICHE ANTIGA

